

QUOTATION FORM

**THE GOVERNMENT OF
THE HONG KONG SPECIAL ADMINISTRATIVE REGION
LEISURE AND CULTURAL SERVICES DEPARTMENT**

**QUOTATION FOR THE GRANT OF A PERMIT TO CONDUCT
LIGHT REFRESHMENT RESTAURANT, LIGHT REFRESHMENT AND
BOAT HIRING BUSINESS AT WONG NAI CHUNG RESERVOIR PARK**

(Quotation Ref. : LRQ LS(S) 90/65/2017(2))

LODGING OF QUOTATION

To be acceptable as a quotation, this form, properly completed in triplicate and enclosed together with other documents of this quotation as shown in Part I below, which must also be properly completed as required in triplicate, in a sealed plain envelope marked "Quotation for the Grant of a Permit to Conduct Light Refreshment Restaurant, Light Refreshment and Boat Hiring Business at Wong Nai Chung Reservoir Park" and addressed to the Chairman, Leisure and Cultural Services Department Quotation Opening Team, must be deposited in/mailed to the Leisure and Cultural Services Department Quotation Box situated at Southern District Leisure Services Office, 4/F, Aberdeen Municipal Services Building, 203 Aberdeen Main Road, Hong Kong

before 12:00 noon (time) on 26 January 2017 (date). Late quotations will not be accepted.

Dated this 6 January 2017 Wicky CHEUNG
Government Representative

Part I — Quotation Documents

These documents under the quotation reference
consist of three (3) complete sets of :

LRQ LS(S) 90/65/2017(2)

- (a) Quotation Form (Sheets 1 to 2);
- (b) Interpretation (Sheets 3 to 6);
- (c) Notes for Service Provider (Sheets 7 to 19);
- (d) Conditions of Contract (Sheets 20 to 66);
- (e) Schedules (Sheets 67 to 90);
- (f) Agreement (Sheet 91); and
- (g) Annexes (Sheets 92 to 97).

Part II — Offer to be Bound

1. Having read the Quotation Documents, I/we agree to be bound by the terms and conditions as stipulated therein.
2. I/We do agree to carry out the Business mentioned in the Conditions of Contract and pay the Monthly Permit Fee as quoted by me/us in the First Schedule, subject to and in accordance with the terms and conditions stipulated in the Quotation Documents.
3. I/We have read Clause 2 Quotation Preparation and Clause 5 Quotation Submission of the Notes for Service Provider and certify that the particulars given by me/us in completing the Quotation Documents are true and correct.

(Notes : The Service Provider **MUST** complete the following parts of the Quotation Documents :

- (i) Quotation Form (Part II – Offer to be Bound); and
- (ii) The First Schedule.)

4. I/We have read Clause 6 Restrictions on Quotation of the Notes for Service Provider, I/ we agree to be bound by the terms and conditions as stipulated therein.

5. In case the Service Provider is a company/firm/body unincorporated, the Service Provider is required to complete 5(a) to 5(c). In case the Service Provider is not a company/firm/body unincorporated, the Service Provider is required to strike out 5(a) to 5(c).

- (a) I am/We are duly authorized to bind the said company hereafter mentioned by my/our signature(s).

– or –

I am a partner/We are partners in the firm hereafter mentioned and duly authorized to bind the said firm and the partners therein for the time being.

- (b) The name of the company/firm/body unincorporated is

A letter certifying the person who signs this quotation is an authorized person to sign contracts/agreements on behalf of the said company/firm/body unincorporated is required to be attached to this Quotation Form. In case the said company is a body corporate, a certified true copy of the company’s Board Minutes/resolution to show that the signatory is duly authorized by the Board of Directors is required to be attached to this Quotation Form.

- (c) The registered office of the company/firm/body unincorporated is situated at

.....

– or –

The names and residential addresses of partners of the firm are as follows :

.....

Name of Service Provider/Authorized Representative *
 (Name in block letters)

Signature of Service Provider/Authorized Representative *
 (Signature) (with Service Provider’s chop, if applicable)

Address(es) of person(s) signing :

Date : _____

- NOTES* : (i) All the particulars required above must be provided.
 (ii) Strike out clearly alternatives which are not applicable.

* Delete as appropriate.

INTERPRETATION

1. The interpretation of the following terms applies to the Quotation Documents and the Agreement unless the context provides otherwise –

‘Agreement’	means the Agreement entered into between the Government and the Permit Holder on the terms and conditions of the Quotation Documents.
‘Business’	means the Permit Holder’s Light Refreshment Restaurant, Light Refreshment and Boat Hiring Business as described in Clause 3 of the Conditions of Contract.
‘Boat Hiring Business’	means the Permit Holder’s Boat Hiring Business as described in Clause 3 of the Conditions of Contract.
‘Boat Hiring Office’	means the area as delineated and shown coloured red in Annex B.
‘Boat Shed’	means the area as delineated and shown coloured red in Annex C.
‘Cap.’	means the Chapter of the Laws of the Hong Kong Special Administrative Region.
‘Monument’	means the dam, valve house and weir of the Wong Nai Chung Reservoir in the Venue which have been declared to be monuments under section 3 of Antiquities and Monuments Ordinance, Chapter 53, and which are delineated and shown edged red in the plan marked Plan No. HKM8609 signed and deposited by the Secretary for Development in the Land Registry a copy of which is produced at Annex F.
‘General Holiday’	means every Sunday and any other day which is a general holiday by virtue of the General Holidays Ordinance (Cap. 149).

‘Government’	means the Government of the Hong Kong Special Administrative Region.
‘Government Representative’	means the Leisure and Cultural Services Department acting for and on behalf of the Government or any duly authorized officer for the purpose of this Agreement.
‘Letter of Acceptance’	means the letter to be issued by the Government Representative to the successful Service Provider accepting the latter’s quotation.
‘Light Refreshment Restaurant Business’	means the Permit Holder’s Light Refreshment Restaurant Business as described in Clause 3 of the Conditions of Contract.
‘Light Refreshment Restaurant’	means the premises used for operation of the Light Refreshment Restaurant Business as delineated and shown coloured red in Annex D.
‘Light Refreshment Kiosk’	means the premises used for operation of the Light Refreshment Business as delineated and shown coloured red in Annex E.
‘Monthly Permit Fee’	means the Monthly Permit Fee quoted by the successful Service Provider in paragraph A of the First Schedule.
‘Permit’	means the permission to conduct the Light Refreshment Restaurant, Light Refreshment and Boat Hiring Business.
‘Permit Area’	means the area as delineated and shown coloured red or yellow in Annexes B, C, D and E.
‘Permit Holder’	means the Service Provider whose quotation for the grant of the Permit is accepted by the Government Representative.
‘Person’	includes any individual, company, corporation, partnership, firm and unincorporated body.
‘Quotation Closing Date’	means the latest date and time by which quotation shall be lodged.

- ‘Quotation Documents’ means the documents as specified in Clause 1 of the Notes for Service Provider.
- ‘Quotation Validity Period’ means the period of one hundred and fifty (150) days or any other period specified by the Government Representative commencing on the Quotation Closing Date during which the quotation is to remain open.
- ‘Security Deposit’ means the deposit which the Permit Holder deposits with the Government in accordance with Clause 8 of the Conditions of Contract for the due and proper performance of the Agreement.
- ‘Service Provider’ means the Person submitting this quotation.
- ‘Term’ means the period during which the Permit is in force and includes any extension thereof as specified in Clause 2 of the Conditions of Contract.
- ‘Venue ’ means the premises as delineated and shown edged green in Annex A.
- ‘Waiting Area’ means the area as delineated and shown coloured yellow in Annex C.

2. In the Quotation Documents and the Agreement, unless the context otherwise requires, the following rules of interpretation shall apply –
- (a) “month” and “monthly” refer to a calendar month.
 - (b) The masculine gender includes the feminine and neuter genders and vice versa.
 - (c) The singular includes the plural and vice versa.
 - (d) Reference to any statute, enactment, order, regulation or other similar instrument shall be construed as a reference to the statute, enactment, order, regulation or instrument as amended by any subsequent statute, enactment, order, regulation or instrument. Reference to a statute or enactment shall include all subsidiary legislation made thereunder.
 - (e) The heading to individual clauses of the Agreement is for ease of

reference only and shall not affect the interpretation or construction of the Agreement.

- (f) If there are discrepancies between the English version and the Chinese version of the Quotation Documents, the English version shall prevail. The Chinese version of the Quotation Documents is for reference only.

THE GOVERNMENT OF THE HONG KONG
SPECIAL ADMINISTRATIVE REGION
LEISURE AND CULTURAL SERVICES DEPARTMENT

NOTES FOR SERVICE PROVIDER

1. Quotation Documents

These documents identified as LRQ LS(S) 90/65/2017(2) consist of THREE (3) complete sets of –

- (a) Quotation Form (Sheets 1 to 2);
- (b) Interpretation (Sheets 3 to 6);
- (c) Notes for Service Provider (Sheets 7 to 19);
- (d) Conditions of Contract (Sheets 20 to 66);
- (e) Schedules (Sheets 67 to 90);
- (f) Agreement (Sheet 91); and
- (g) Annexes (Sheets 92 to 97).

2. Quotation Preparation

- (a) A Service Provider MUST submit the following –
 - (i) a signed Offer to be Bound in the Quotation Form; and
 - (ii) the quotation of Monthly Permit Fee as required in the First Schedule.
- (b) A Service Provider who fails to submit all or any of the above items specified in Clause 2(a)(i) or (ii) above shall render his quotation invalid.
- (c) A Service Provider must submit all Quotation Documents in TRIPLICATE in the manner stipulated under ‘Lodging of Quotation’ in the front page of the Quotation Form.
- (d) When completing the Quotation Documents, any alteration in figures or words shall be effected by striking through the incorrect figures or words and inserting the corrected ones above the original ones. All such amendments shall be initialed by the Service Provider in ink.

Any unauthorized alteration or erasure to the text of the Quotation Documents may cause the quotation to be rejected.

- (e) Subject to paragraph (a) above and Clause 14 hereof, the quotation may be rejected if information required in the Schedules other than the First Schedule is not given with the quotation or if any particulars and data asked for in this quotation are not furnished in full or if any necessary supporting documents required to be provided are not submitted with the quotation.

3. Service Provider's Status

- (a) If the Service Provider is a sole proprietor, the Service Provider shall answer queries and sign the Quotation Documents personally and shall not authorize any other person to act for the Service Provider. If the Service Provider is a firm or an unincorporated body, the Service Provider may authorize a partner(s) of the firm or an office-bearer of a body unincorporated to answer queries and sign the Quotation Documents.
- (b) If the Service Provider is an unincorporated firm or organization, a company or other incorporated body, he shall submit with the quotation a copy of the minutes of meeting and/or resolution of the board of directors to prove proper authorization of the person(s) or representative(s) to act on behalf of the Service Provider and sign the Quotation Documents. If the Service Provider is a partnership, one of the partners may sign the Quotation Documents save and except that all partners shall execute the Permit.

4. Checklist for Potential Service Provider before Submission of Quotation

To ensure completeness and consistency of the information provided, potential Service Provider is recommended to complete the "Checklist for Potential Service Provider for Revenue Contracts before Submission of Quotation".

5. Quotation Submission

- (a) Completed Quotation Documents shall be enclosed in a sealed

envelope clearly marked with the quotation reference and the subject of the quotation on the outside of the sealed envelope and that the sealed envelope shall not bear any indication which may relate the quotation to the Service Provider or any particular contractor / supplier / service provider and addressed to the Chairman, Leisure and Cultural Services Department Quotation Opening Team. **They shall be deposited in or mailed to the Leisure and Cultural Services Department Quotation Box located at the Southern District Leisure Services Office, 4/F, Aberdeen Municipal Services Building, 203 Aberdeen Main Road, Hong Kong before 12:00 noon on the Quotation Closing Date.**

- (b) In case a black rainstorm warning signal or tropical cyclone warning signal no. 8 or above is issued between 9:00 a.m. and 12:00 noon on the Quotation Closing Date, the closing time of this quotation will be deferred to 12:00 noon on the next weekday (i.e. except Saturday and Sunday) other than a General Holiday and after the black rainstorm warning signal or tropical cyclone warning signal no. 8 or above is cancelled.
- (c) The Government Representative shall not be responsible for any mislaid quotation or any quotation submitted by methods other than as indicated under this clause.

6. Restrictions on Quotation

- (a) A quotation shall only be accepted from any Person who shall occupy the Permit Area for his own use. There shall be no assignment, underletting or parting with the possession of the whole or any part of the Permit Area unless the Government Representative approves in writing otherwise.
- (b) (1) By submitting a quotation, the Service Provider represents and warrants that in relation to the quotation -
 - (i) it has not communicated and will not communicate to any Person other than the Government the amount of Monthly Permit Fee;

- (ii) it has not fixed and will not fix the amount of Monthly Permit Fee by arrangement with any Person;
 - (iii) it has not made and will not make any arrangement with any Person as to whether it or that other Person will or will not submit a quotation; and
 - (iv) it has not otherwise colluded and will not otherwise collude with any Person in any manner whatsoever in the quotation process.
- (2) In the event that the Service Provider is in breach of any of the representations and/or warranties in sub-clause (1) of this clause, the Government Representative shall be entitled to, without compensation to any Person or liability on the part of the Government-
- (i) reject the quotation; or
 - (ii) if the Government has accepted the quotation, withdraw its acceptance of the quotation; or
 - (iii) if the Government Representative has entered into the contract with the Service Provider, terminate the contract.
- (3) The Service Provider shall indemnify and keep indemnified the Government against all losses, damages, costs or expenses arising out of or in relation to any breach of any of the representations and/or warranties in sub-clause (1) of this clause.
- (4) Any breach of any of the representations and/or warranties in sub-clause (1) of this clause by the Service Provider may prejudice the Service Provider's future standing as a Government contractor.
- (5) Sub-clause (1) of this clause shall have no application to the Service Provider's communications in strict confidence with his own insurers or brokers to obtain an insurance quotation for

computation of the Monthly Permit Fee or with his professional advisers or consultants to solicit their assistance in preparation of quotation submission.

- (6) The rights of the Government under sub-clauses (2) to (4) of this clause are in addition to and without prejudice to any other rights or remedies available to it against the Service Provider.

7. Quotation Documents of Unsuccessful Service Provider

Quotation Documents of unsuccessful Service Provider will be destroyed three (3) months after the date the Agreement has been constituted under Clause 16 hereof.

8. Undisclosed Agency

The Person who signs a quotation as Service Provider shall be deemed to be acting as a principal unless he discloses therein that he is acting as an agent only, in which case he shall also disclose therein the name and address of his principal. **If there is a written partnership agreement, the Service Provider shall attach a copy of it to the Quotation Documents.**

9. Memorandum and Articles of Association

The Service Provider which is a company incorporated under the Companies Ordinance (Cap. 622) shall attach a copy of the Articles of Association to the Quotation Documents. A Service Provider which is a company incorporated under any of the former Companies Ordinances shall attach a copy of each of the Memorandum of Association and Articles of Association to the Quotation Documents.

10. Business Registration Certificate

If the Service Provider is currently running a firm/company, a copy of the valid Business Registration Certificate which bears a machine-printed line to show that full registration fee has been paid shall be attached to the quotation.

11. Service Provider's Response to Government Representative's Enquiries

In the event that the Government Representative determines that clarification of any quotation is necessary, it will advise the Service Provider accordingly indicating whether the Service Provider shall supplement his quotation. The Service Provider shall thereafter within seven (7) working days or such period as specified in the request for clarifications submit such information in the manner as requested by the Government Representative.

12. Monthly Permit Fee

- (a) **The Service Provider must state in paragraph A of the First Schedule the Monthly Permit Fee for the Light Refreshment Restaurant, Light Refreshment and Boat Hiring Business payable throughout the Term of the Agreement that he wishes to offer.**
- (b) **The Monthly Permit Fee does not include rates, Government rent and taxes payable in respect of the Permit Area and the Light Refreshment Restaurant, Light Refreshment and Boat Hiring Business.**
- (c) The Monthly Permit Fee shall be expressed in Hong Kong dollars.

13. Security Deposit

- (a) If the quotation is accepted in accordance with Clause 14 hereof, the successful Service Provider shall not later than seven (7) days before the commencement of the Term or at such time as shall be directed by the Government Representative, deposit with the Government the sum of money as indicated in paragraph 1 of the Third Schedule as security for the due and faithful performance of the Agreement either in cash or in the form of a banker's guarantee approved by the Government Representative and issued by a bank licensed under Section 16 of the Banking Ordinance (Cap. 155). If the Security Deposit is provided in the form of a banker's guarantee, the successful Service Provider shall keep the Security Deposit valid for three (3) more months after the expiry of the Agreement.

- (b) If the successful Service Provider fails to pay the Security Deposit by the due date aforesaid, the Government Representative shall immediately thereupon be at liberty to take action outlined in Clause 8(b) of the Conditions of Contract.

14. Selection of Quotation

(a) **Mandatory requirements —**

- (i) **The Service Provider shall note that his quotation shall be rejected if he fails to complete and sign on Part II of the Quotation Form - Offer to be Bound, or fails to provide the Monthly Permit Fee in the First Schedule.**
- (ii) **The Service Provider must have at least two (2) years of experiences within the past ten (10) years prior to the Quotation Closing Date in operating boat hiring business and also in either operating fast food, light refreshment restaurant or general restaurant business and boat hiring business.**

Notes :

- i) The Service Provider's experience must be gained as an owner of the business in operating fast food, light refreshment restaurant or general restaurant business and boat hiring business.
- ii) Experience gained outside Hong Kong will not be counted.
- iii) If the Service Provider is a partnership or incorporated joint venture, only the years of partnership or joint venture experience gained by that partnership or incorporated joint venture, but not the individual experience of the participants to the partnership or parties of incorporated joint venture, will be counted.
- iv) Experience gained over overlapping period will be counted once only. Experience need not be continuous.
- v) The Quotation Closing Date will be the cut-off date for calculation of

years of experience. Experience obtained in different contracts/venues during overlapping periods will be counted once only.

vi) Documentary proof such as a copy of the contract agreement for relevant business showing the agreement description, the agreement commencement and expiry dates and the scope of the business, shall be provided by the Service Provider to substantiate the past experience claimed in the quotation. Otherwise, the relevant claimed past experience will not be taken into account.

(iii) A Service Provider who submits a proposal to assign, underlet or part with the whole or any part of the Permit Area shall be rejected by the Government and will render his offer invalid.

(b) Price evaluation —

A Service Provider shall note that the quotation will be evaluated according to the price information provided in the First Schedule.

15. Basis of Acceptance

(a) The Government Representative is not bound to accept the highest or any quotation or to give any reasons for doing so, and reserves the right to accept all or any part of a quotation at any time within the Quotation Validity Period.

(b) A Service Provider shall note that his offer will be considered on a complete overall basis. Quotations with only partial offers shall be rejected.

16. Award of Contract

(a) The successful Service Provider will be issued as an indication of acceptance a fax or a Letter of Acceptance prior to the receipt of the duplicate copy of the Quotation Documents with the “Agreement” duly completed. Upon issue of the aforesaid fax or Letter of Acceptance, a binding contract is constituted between the parties.

- (b) A Service Provider who does not receive any notification within one hundred and fifty (150) days or any other period specified by the Government Representative of the Quotation Closing Date shall assume that his quotation has not been accepted.

17. Quotation to Remain Open

- (a) A quotation submitted shall remain valid and open for acceptance on these terms for not less than one hundred and fifty (150) days or any other period specified by the Government Representative commencing on the Quotation Closing Date.
- (b) If before expiry of the Quotation Validity Period, a Service Provider withdraws his offer, the Government will take due notice of the Service Provider's action and this may prejudice his future standing as a Government contractor.

18. State of Premises

The successful Service Provider shall arrange with the Government Representative to inspect the Permit Area at a reasonable time and the Permit Holder shall accept the Permit Area in the state and condition in which they are at the date on which occupancy is given.

19. Use of Personal Data

All personal data submitted by the Service Provider will be used for the purpose of this quotation only.

20. Site Visit and Quotation Briefing

A quotation briefing and site visit session will be held at 3:00 p.m. on 13 January 2017 (Friday) in the Conference Room of Southern District Leisure Services Office (SDLSO)(4/F, Aberdeen Municipal Services Building, 203 Aberdeen Main Road, Hong Kong). Service Provider is invited to attend the quotation briefing and site visit session before submitting his quotation in order to acquaint himself with the terms and conditions of the quotation. For registration, please contact Manager (Parks and Playgrounds) Southern 2, Leisure and Cultural Services

Department at 2553 0742 for reservation of seat for the quotation briefing and visit by 5:00 p.m. on 11 January 2017 (Wednesday).

21. **Termination of Agreement**

A Service Provider shall note that after the commencement of the Agreement, either the Government Representative or the successful Service Provider may terminate the Agreement by serving to the other party a six (6) months' prior notice in writing specifying the date of termination provided that the said date of termination shall be a date at least eighteen (18) months after the commencement of the Agreement.

22. **Offering Gratuities**

The Service Provider shall not and shall ensure that his agents and employees shall not offer or give any advantage as defined in the Prevention of Bribery Ordinance (Cap. 201) to any agent or employee of the Government. Any breach of or non-compliance with this clause by the Service Provider shall, without affecting the Service Provider's liability for such breach or non-compliance, invalidate his quotation, and if the Agreement has been awarded to the Service Provider without knowing the breach, the Government shall be entitled to immediately terminate the Agreement and claim for all losses and costs incurred from the Service Provider.

23. **Consent to Disclosure**

The Government has the right to disclose whenever it considers appropriate or upon request by any third party (written or otherwise) information on the awarded contract, without any further reference to the successful Service Provider, the name and address of the successful Service Provider, description of services and the contract amount.

24. **Cancellation of Quotation**

Without prejudice to the Government's right to cancel the quotation, where there are changes of requirement after the Quotation Closing Date for operational or whatever reasons, the Government is not bound to accept

any conforming quotation and reserves the right to cancel the quotation.

25. Cost of Quotation

A Service Provider shall submit his quotation proposal at his own cost and expense. The Government will not be liable for any costs and expenses whatsoever incurred by the Service Provider in connection with the preparation or submission of his quotation or in any related communication with the Government whether before, on or after the Quotation Closing Date.

26. Complaint about Quotation Process or Contract Award

The quotation process is subject to internal monitoring to ensure that the Agreement is awarded properly and fairly. Any Service Provider who feels that his offer has not been fairly evaluated may write to the Director of Leisure and Cultural Services who will personally examine the complaint and refer it to the relevant quotation boards for consideration if it relates to the quotation system or procedures followed. For quotations not covered by the WTO GPA, the Service Provider shall lodge the complaint before disposal of documents of unsuccessful Service Provider, which shall be three (3) months after the award of Agreement.

27. Provision of Services within the Venue

A Service Provider shall note that the Government Representative is entitled to provide or allow any Person or contractor to provide drinking fountain, light refreshment and/or vending machine service within any other areas of the Venue during the Term of the Agreement. The Permit Holder is therefore not entitled to claim for abatement of Monthly Permit Fee or any part thereof on the ground that the Light Refreshment Restaurant Business is affected by such arrangement.

28. Application for Appropriate Food Licences

- (a) A Service Provider shall note that it is the Permit Holder's sole responsibility to approach the relevant authorities for obtaining all licences, permits and/or certificates required by the law for operation of his Light Refreshment Restaurant Business at the Permit Area.

The Permit Holder shall note that it will be unlawful for him to sell any commodity for which any licence, permit and/or certificate is required without first obtaining such licence, permit and/or certificate.

- (b) The Permit Holder shall note that since it will necessarily take time for the relevant authorities to consider and decide on an application for a licence, permit and/or certificate, the Permit Holder is therefore not entitled to claim for abatement of the Monthly Permit Fee on the grounds that he cannot operate his Light Refreshment Restaurant Business pending the issue of the relevant licences, permits and/or certificates.
- (c) For activities relevant to licensing requirements regulated by the Director of Food and Environmental Hygiene, the Permit Holder shall visit the following Food and Environmental Hygiene Department's website for more information -

http://www.fehd.gov.hk/english/licensing/Guide_on_Types_of_Licences_Required.html

29. Successful Service Provider's Performance Monitoring

A Service Provider is advised that should he be awarded the Agreement, his performance under the Agreement will be monitored and shall be taken into account in the evaluation by the Government of quotations/tenders submitted by him for any goods or services procured by the Government in future. An offer or quotation submitted by a Service Provider who has been in breach of any of his statutory obligations or contractual obligations under any comparable contracts with the Government (whether current or past) may not be considered having regard, including but not limited to, the seriousness and the number of breaches and its or their relevancy to the offer or quotation submitted. The decision of the Government whether or not to consider the quotation submitted by a Service Provider under circumstances described in this provision shall be final.

30. Negotiation

The Government reserves the right to negotiate with any Service Provider on the terms of the Quotation Documents including but not limited to the Monthly Permit Fee offered by the Service Provider.

31. Quotation Addendum

The Government may issue addendum to the terms and conditions of the Quotation Documents. Service Provider may be asked to confirm compliance with the terms and conditions issued under the Quotation Documents or those issued under any addendum thereto.

CONDITIONS OF CONTRACT

Contents

1. Nature of the Permit
2. The Term
3. The Business
4. Hours of Business
5. Conduct of Business
6. Monthly Permit Fee
7. Abatement
8. Security Deposit
9. Advancement, Deferment and Suspension of Business
10. Resumption of Business
11. Permit Holder's Warranties and Undertakings
12. Cleansing, Collection and Disposal of Refuse and Litter
13. Monies or Valuables Found or Property Lost
14. Permit Holder's Employees or Agents
15. Publicity and Advertisement
16. Notices to be Displayed or Circulated in the Venue
17. Water Supply
18. Electricity Supply
19. Rights Reserved by Government Representative
20. Sale and Hire of Commodities
21. Display of Commodity Prices
22. Erection of Structure
23. Watchman
24. Use of Fuel
25. Store of Dangerous Goods and Prohibited Goods
26. Fire Fighting Equipment
27. Discharge of Waste Water
28. Sale of Alcoholic Liquor
29. Arrangement During Epidemic Illness
30. Government Premises, Property, Machinery and Equipment
31. Access Granted to the Permit Holder
32. Inconvenience or Annoyance Caused at the Venue
33. Inspection and Rejection
34. Permit Holder's Act, Default, etc.
35. Accident to Permit Holder's Employees
36. Liability and Indemnity

37. Public Liability Insurance
38. Failure to Insure
39. Corrupt Gifts
40. Termination
41. Effect of Termination
42. Recovery of Sums Due
43. Jurisdiction
44. Licence, Permit and/or Certificate
45. Applicability of Public Health and Municipal Services Ordinance
46. Compliance with Law and Government Requirements
47. Service of Notice
48. Waiver of Remedies
49. Severability
50. Relationship of the Parties
51. Mediation
52. Entire Agreement
53. Exclusion

CONDITIONS OF CONTRACT

1. Nature of the Permit

- (a) It is expressly agreed between the parties that this Permit creates no tenancy or lease or any form of legal rights on land whatsoever between the parties except the permission to use the Permit Area in accordance with the provisions of the Agreement.
- (b) The Permit granted to the Permit Holder is personal to him and unless with the prior consent in writing from the Government Representative, the Permit Holder shall not assign, sublet, part with the possession of the whole or any part of the Permit Area or transfer any of his rights or obligations under the Agreement.

2. The Term

- (a) Subject to Clause 9 hereof, the Term shall commence on the 1st day of April 2017 and, subject to prior termination and extension as are hereinafter provided, shall expire on the 31st day of March 2020, both dates inclusive.
- (b) The Government Representative shall be entitled to extend the Term for a maximum period of six (6) months upon its expiration by giving the Permit Holder one (1) month's advance notice in writing before the due expiration of the Term.
- (c) If a notice is given by the Government Representative under Clause 2(b) above, the Permit Holder shall continue to conduct his Light Refreshment Restaurant, Light Refreshment and Boat Hiring Business for the whole period specified in the notice on the same terms and conditions as herein contained (save and except this clause on extension).
- (d) If the commencement date of the Term shall be advanced or deferred under Clause 9(a) hereof, the expiry date of the Term shall be advanced or deferred accordingly with length of the Term remains unchanged.

3. The Business

Subject to the terms and conditions of the Agreement, the Government grants to the Permit Holder during the Term the permission to conduct the business of providing —

- (a) the hiring out of row boats, pedal wheel boats and radio-controlled & battery-operated model boats (“the Boats”) and such other facilities related to the boat hiring business as may be approved by the Government Representative within the Venue (the “Boat Hiring Business”) and
- (b) the sale of light refreshment items and commodities set out in Second Schedule A within a Light Refreshment Kiosk and food items set out in the Second Schedule B within a Light Refreshment Restaurant (“the Light Refreshment Restaurant and Light Refreshment Business”), (a) and (b) collectively called the “Business”
- (c) at the following premises —
 - (1) an office area of about 7.8 square metres as delineated and shown colour red in Annex B (the “Boat Hiring Office”);
 - (2) a boat shed of about 36.4 square metres as delineated and shown colour red in Annex C (the “Boat Shed”);
 - (3) a waiting area of about 26.7 square metres as delineated and shown colour yellow in Annex C (the “Waiting Area”);
 - (4) a light refreshment restaurant of about 69.1 square metres as delineated and shown colour red in Annex D (the “Light Refreshment Restaurant”) and
 - (5) a light refreshment kiosk of about 25.9 square metres as delineated and shown colour red in Annex E (the “Light Refreshment Kiosk”).

hereinafter collectively referred to as the “Permit Area”.

4. Hours of Business

- (a) Subject to the terms and conditions of the Agreement, the Permit Holder shall carry out his Business at the following hours -

<u>Month</u>	<u>Daily Business Hours</u>
(i) May to September	9:00 a.m. to 7:00 p.m.
(ii) October to April	9:00 a.m. to 6:00 p.m.

- (b) The Government Representative is entitled to revise at any time and from time to time the business hours of the Business as specified in Clause 4(a) above.
- (c) The Permit Holder shall not vary the business hours of his Business unless prior written consent of the Government Representative has been obtained.
- (d) The Permit Holder shall not be entitled to any adjustment or abatement of the Monthly Permit Fee for any change of the business hours referred to in this clause and shall pay the Monthly Permit Fee in pursuant to Clause 6 below under all circumstance.

5. Conduct of Business

- (a) The Permit Holder shall conduct his Business only at the Permit Area and shall maintain the Permit Area an efficient and adequate service of a style, type and quality to the satisfaction of the Government Representative.
- (b) The Permit Holder shall use the Permit Area only for his Business and shall not use, cause, suffer or permit to be used the Permit Area or any part thereof as sleeping quarters or domestic premises or for any other purposes.
- (c) The Permit Holder shall conduct his Business only at the Permit Area and shall not use, cause, suffer or permit to be used any area of the Venue except the Permit Area for such purpose or for any other purposes.

- (d) The Permit Holder may provide chairs of a design, quality and quantity as first approved by the Government Representative within the Waiting Area for use of hirers during opening hours as specified in clause 4(a) above for his Business. Provided always that the Permit Holder shall keep and maintain at all times all such chairs in good repair and condition to the satisfaction of the Government Representative and shall maintain the Waiting Area and their immediate surroundings in clean, tidy and presentable condition to the satisfaction of the Government Representative.
- (e) Conduct of Boat Hiring Business, Hire of Row Boats, Pedal Wheel Boats and Radio Controlled & Battery-Operated Model Boats

The Permit Holder shall-

- (i) provide a minimum of ten (10) row boats, twenty (20) pedal wheel boats and ten (10) radio controlled & battery-operated model boats (the “model boats”) for hire. A total number of thirty (30) row boats and pedal wheel boats and ten (10) model boats are allowed to be hired at any one time during the business hours in the Venue.
- (ii) ensure that all the Boats are conform to the design and specification set out in the Fifth Schedule (a deviation within 10% of the total dimensions of any one type of the Boats as specified in the Fifth Schedule is acceptable) or of such other design as the Government Representative may approve. The frequency of the radio-controlled transmitter should conform to the requirements given by the Director-General of Communications.
- (iii) not introduce into or have in the Permit Area any boats not listed in the Fifth Schedule or in respect of which the Government Representative has not previously given its permission in writing for such introduction.
- (iv) ensure that all the Boats for hire in the Permit Area are in good and serviceable conditions.
- (v) permit the Government Representative to inspect the Boats

in the Permit Area. The Government Representative reserves the right to forbid any boats which are not in a condition acceptable to the Government Representative for hire in the Permit Area (“banned boats”).

- (vi) not use any banned boats until repairs have been carried out to the satisfaction of the Government Representative and the Government Representative has by notice in writing revoked the ban in respect thereof.
- (vii) keep sufficient stock of spare parts and accessories at all times for immediate repairs to the general fittings and attachments of the Boats in the Fifth Schedule.
- (viii) not allow any boats to be built in the Permit Area and not permit any boats other than those to be used in pursuant of this Agreement to be repaired in the Permit Area.
- (ix) number the Boats with prominent and conspicuous markings bearing Arabic figures according to the serial number of that boat as listed in the Fifth Schedule A.
- (x) mark the Boats with prominent and conspicuous indicator in both English and Chinese with the words “MAXIMUM *ONE/TWO/FOUR PERSON(S) ONLY” and the characters “祇限 *一/二/四人” as appropriate and ensure that at all times the Boats in use carry no more than the maximum number of passengers as allowed and indicated on the Boats.
- (xi) not alter the dimensions or structure of the Boats described in the Fifth Schedules without the prior permission of the Government Representative in writing and in any event boats of a length exceeding 3.6 metres should not be used.
- (xii) not permit any person under fourteen (14) years of age to hire the Boats and in no circumstances permit children in arms to be carried into any of the Boats. Notices to this effect shall be posted at prominent positions.
- (xiii) not permit persons to take intoxicating liquor or pills on

board any of the Boats.

- (xiv) employ a manager or designate a person whom the Government Representative can approach or contact all times during the business hours.
- (xv) ensure the Boats are properly maintained, safe and at sound condition at all times and be responsible for recovering capsized model boats in the water.
- (xvi) not use the Boat Shed or any part thereof for any purpose whatsoever other than for storage of the Boats.

(f) Provision of Life-saving Services

The Permit Holder shall-

- (i) have, in the Permit Area, at least one inflatable rescue boat equipped within a 4-strokes outboard motor of twenty-five (25) horsepower with propeller guard and a life buoy fitted with a lanyard of not less than fifteen (15) metres in length both in good and serviceable condition and bearing all necessary permits.
- (ii) The inflatable rescue boat shall be stand-by afloat at all times during the business hours of Boat Hiring Business. Employ a person who is qualified to operate the inflatable rescue boat and shall be on duty in the Permit Area at all times during the business hours.
- (iii) employ such qualified lifeguards (Beach Lifeguard Award holder) as may be approved by the Government Representative and to have a minimum of two (2) such lifeguards at all time during the business hours of Boat Hiring Business.
- (iv) ensure all lifeguards shall wear uniforms bearing the words 'Lifeguard' and the characters '救生員' when they are performing lifeguard duties in the Permit Area.

- (v) provide a lookout tower of the materials and design approved by the Government Representative and to be erected at the position as indicated in Annex A in brown and have a lifeguard on duty on the said tower at all times during the business hours of the Boat Hiring Business.
- (vi) provide proper resuscitation and first aid equipment as specified in the Sixth Schedule to the satisfaction of the Government Representative and maintain the same in good and serviceable condition at all times. The Permit Holder shall ensure that there are staff in the Venue who are able to use Automated External Defibrillator (AED) provided in the Venue for emergency case. Related training shall be provided by the Permit Holder to the staff at his own cost when necessary.
- (vii) have at all times in a conspicuous position in the Venue a device on which a recall signal may be issued, and shall in the event of the issue by the Hong Kong Observatory of a tropical cyclone warning signal no. 1 or Strong Monsoon Signal, Yellow Rainstorm Warning, or Thunderstorm Warning display a recall signal and ensure that all the Boats are placed and secured on land.
- (viii) stop all boating activities and recall all boats in foggy weather or in conditions of poor visibility.
- (ix) mark out with a boom line, at the Permit Holder's expenses, the extent of the boating activities area as directed by the Government Representative.
- (x) provide a boom with warning signs and red lighting five (5) metres from the dam in the reservoir and ensure that no person could enter the area between the boom and the dam whether in a boat or otherwise.
- (xi) provide life buoys in good and serviceable condition at intervals not more than fifty (50) metres apart throughout the periphery of the water area of the Venue.

- (xii) provide free of charge and require each person on board a boat to wear a life jacket of I.S. EN ISO 12402-3:2006 or EN 296-150N, such life jackets shall be maintained in good and proper condition acceptable to the Government Representative at all times.
- (xiii) provide safe and adequate landing/embarkation facilities for hirers to board/disembark from boats, and provide two (2) life buoys with lanyards of not less than fifteen (15) metres in length at each boarding/landing point.
- (xiv) not allow any person to embark or disembark on any pretext whatsoever except at the designated landing pontoon.
- (xv) provide a receptacle in each row boat and pedal wheel boat for the hirer to deposit litter whilst boating. All litter so collected shall be emptied at least once per day.
- (xvi) provide sufficient number of lifejackets of standards as specified in sub-clause (xii) above and buoyancy aids in different sizes which shall suit adult, juniors and children with different body sizes.
- (xvii) prominently display a large sign board of no less than 1m x 0.6m with a map showing the water activities area and safety advices to the hirers and passengers at the Waiting Area.

6. Monthly Permit Fee

- (a) The Permit Holder shall pay to the Government in advance a Monthly Permit Fee as specified in paragraph A of the First Schedule on the 15th day of each and every month without any reduction throughout the Term.
- (b) The Monthly Permit Fee does not include rates, Government rent and taxes payable in respect of the Permit Area.
- (c) Notwithstanding Clause 6(a) above, the first payment of the Monthly Permit Fee is to be made not later than seven (7) days before the

commencement of the Term or at such time as shall be directed by the Government Representative.

- (d) When payment of the Monthly Permit Fee of any month is overdue, the Permit Holder shall pay to the Government a surcharge on that outstanding Monthly Permit Fee at an interest rate equivalent to the average of the best lending rate of the three note-issuing banks in Hong Kong plus 2% per annum. Such interest shall be calculated and payable from the day on which such payment falls due.

7. Abatement

If the Government Representative shall require a closure of the Permit Area or a suspension of the Permit Holder's Business under Clause 19(b) hereof for a continuous period of more than seven (7) days or a deferment of the commencement of the Term under Clause 9 hereof, the Monthly Permit Fee will abate, notwithstanding Clause 6 hereof, for the total period of such closure or suspension or deferment on a pro rata basis.

8. Security Deposit

- (a) The Permit Holder shall, at least seven (7) days before the commencement of the Term or any extension thereof, deposit with the Government in cash or in the form of a banker's guarantee approved by the Government Representative and issued by a bank licensed under the provisions of the Banking Ordinance (Cap. 155), a sum equivalent to four (4) times the Monthly Permit Fee as security for the due and proper performance of the Agreement. The Permit Holder shall keep the aforesaid Security Deposit, if it is provided in the form of a banker's guarantee, valid for three (3) more months after the expiry of this Agreement.
- (b) If the Permit Holder fails to pay the Security Deposit upon the due date as stipulated in Clause 8(a) above or refuses to carry out the Agreement upon the commencement of the Agreement, the Agreement shall be deemed to be terminated and the Government Representative is entitled to grant the Permit to another Person and claim for compensation from the Permit Holder.

- (c) The Security Deposit in cash shall be wholly forfeited to the Government or a call shall be made on the banker's guarantee in the event of the Agreement being terminated in accordance with Clause 40(a) hereof. Notwithstanding such provisions and without prejudice to any other remedies available to the Government, the Government Representative shall have the right to deduct from the Security Deposit in cash or to make a call on the banker's guarantee in order to pay the Government the amount in relation to any losses, claims, damages, costs, charges, expenses, liabilities, demands, proceedings and actions whatsoever suffered by the Government as the direct or indirect result of any breach of the Agreement by the Permit Holder.
- (d) If any deduction is made by the Government Representative from the cash deposit or by making a call on the banker's guarantee during the continuance of the Agreement, the Permit Holder shall, within fourteen (14) days, on demand in writing made by the Government Representative, deposit a further sum or provide a further banker's guarantee in a sum equal to the amount so deducted or so called on, and such sum shall be added to the residue of and form part of the Security Deposit.
- (e) Subject to Clause 42 hereof, upon the expiry or sooner termination of the Agreement, the Government Representative will return to the Permit Holder without interest the balance of the Security Deposit or the banker's guarantee, if one is provided, shall be released within three (3) months if all of the Permit Holder's obligations under the Agreement have been observed and complied with to the satisfaction of the Government Representative and the receipted bills in respect of outstanding payment of all fees and charges including rates and utility charges are provided to the Government, notwithstanding the expiry of the Term.

9. Advancement, Deferment and Suspension of Business

- (a) Notwithstanding the provision of Clause 2 hereof and any other provisions of the Agreement, the Government Representative shall be entitled to advance or defer the commencement date of the Term for whatsoever reasons and for such period as the Government

Representative shall in its sole discretion decide.

- (b) If there shall be such advancement or deferment of commencement of the Term under this clause –
 - (i) The Government shall not be liable for any losses suffered or expenses incurred whatsoever by the Permit Holder due to such deferment or termination under Clause 9(b)(ii).
 - (ii) Upon the expiry of such period of deferment and without further notification by the Government Representative of the commencement of the Term, the Agreement shall terminate automatically. The Government Representative will return to the Permit Holder without interest the balance of the Security Deposit and any Monthly Permit Fee already paid in advance.
 - (iii) The Government Representative shall, so far as it is practicable in the circumstances, give the Permit Holder notice of advancement of the commencement of the original Term in writing at least fourteen (14) days prior to the revised commencement date of the Term.
 - (iv) The Government Representative shall, so far as it is practicable in the circumstances, give the Permit Holder notice of deferment in writing at least fourteen (14) days prior to the original commencement date of the Term.
- (c) If the commencement of the Term has been advanced under Clause 9(a), the Monthly Permit Fee shall be paid in accordance with Clause 6(c) hereof.
- (d) If the commencement of the Term has been deferred under Clause 9(a), the Monthly Permit Fee shall be adjusted in accordance with Clause 7 hereof.
- (e) The Permit Holder may suspend his Business for a reasonable period of time when the weather conditions warrant such suspension in view of the safety of his employees. Prior approval from the Government Representative shall be obtained as far as it is

practicable in the circumstances and the Government Representative's decision on the duration of such period of suspension shall prevail.

10. Resumption of Business

If the Permit Holder's Business shall be suspended under the terms and conditions of the Agreement, he shall resume his Business immediately within the period specified under the Agreement or that specified by the Government Representative, as the case may be.

11. Permit Holder's Warranties and Undertakings

The Permit Holder warrants and undertakes to the Government Representative that –

- (a) he shall produce his Business Registration Certificate or Certificate of Incorporation, as the case may be, upon demand by the Government Representative;
- (b) he shall use only those appliances, fixtures and fittings which have previously been approved by the Government Representative. He shall not make any alteration or addition to any of the appliances, furniture, fixtures or fittings therein or the decoration thereof without the prior permission in writing by the Government Representative, and he shall not carry out the repairs to the appliances, furniture, fixtures and fittings supplied by the Government without first obtaining the approval of the Government Representative. Subject to such approval being sought, the relevant works shall be carried out at the expenses of the Permit Holder by workers approved by and to a standard acceptable to the Government Representative;
- (c) he shall take all reasonable precautions to protect the Permit Area from damage by fire, storm, tropical cyclone or the like;
- (d) he shall maintain the Permit Area and its surroundings in a clean, tidy and serviceable condition to the satisfaction of the Government Representative and if in the opinion of the Government Representative the Permit Holder fails to do so, the Government

Representative may without notice close the Permit Area and suspend the Permit Holder's Business for a period or periods not exceeding seven (7) days on any one (1) occasion to cause the Permit Area and its surroundings to be cleaned and serviced and the Permit Holder shall pay the costs thereof to the Government Representative on demand and shall remain liable to pay the Monthly Permit Fee to the Government without any deduction;

- (e) he shall not use the Permit Area or any part thereof, or cause, or permit, or suffer the same to be used for any illegal, immoral purpose, gambling or any other purposes not permitted under the Agreement;
- (f) he shall not permit any games to be played in the Permit Area including but not limited to mahjong and tin kau whether for gambling purposes or otherwise;
- (g) he shall not permit the Permit Area to be used as a changing room by users of the Venue or other members of the public;
- (h) he shall not cause or permit any floorshow or any type of entertainment to be staged in the Permit Area or its vicinity;
- (i) he shall permit the Government Representative and its agents at all times to have unimpeded access to all parts of the Permit Area to examine the conditions thereof and to execute repairs thereto;
- (j) he shall assume full responsibility for the safety of all operations and methods of operations;
- (k) he shall provide and maintain at all times properly insulated and refrigerated containers solely for the storage of frozen confections and shall store in such insulated and refrigerated containers all frozen confections available for sale in the Permit Area;
- (l) he shall keep all articles of food stored or offered for sale at the Permit Area effectively protected against flies, cockroaches, vermin, dust and dirt and shall sell pastries, bread, biscuits, cakes, preserved foodstuffs and sweets only in their original wrappers and in such

hygienic condition as is reasonably practicable;

- (m) he shall not stock, sell or provide at the Permit Area any cigarettes, cigars or tobacco products whatsoever;
- (n) he shall not sell or offer for sale any liquid refreshment other than in sterile drink cups;
- (o) he shall cleanse and immerse in boiling water for not less than one (1) minute and allow to dry by evaporation before each use of crockery, cutlery and utensils used in the preparation or serving of food or drinks and when not in use to store such implements in vermin-proof and dust-proof cupboards;
- (p) he shall be responsible for the safety of any vehicles which he uses or brings alongside or onto the Venue and he shall indemnify the Government in respect of any losses or damages thereto as a result of the use of such vehicles;
- (q) he shall pay all the costs and deposits of all telephone installed, electricity or water supplied to the Permit Area, and shall pay all rates, Government rent, taxes, fees, charges and outgoings whatsoever now or hereinafter payable in respect of the Permit Area and his Business;
- (r) he shall not request or receive any charge or fee from any Person for admission to the Permit Area or its surroundings, nor request or receive any other additional charge whether by way of service charge or otherwise;
- (s) he shall on receipt of forty-eight (48) hours' notice from the Government Representative to produce to it for inspection of the books, ledgers, vouchers, receipts and other documents relating to his Business, and to make available copies of the same to the Government Representative, if required;
- (t) he shall not later than thirty (30) days after the expiry of each month during the continuance of this Agreement and not later than thirty (30) days after the termination of this Agreement howsoever caused,

submit to the Government Representative a statement of account in the form as the parties hereto may mutually agree, or in default of agreement as the Government Representative may from time to time prescribe, showing the gross monthly turnover of the Business, for that month. For the purpose of these provisions “gross monthly turnover of the Business” shall mean the gross proceeds or receipts as received or receivable for any food and/or drinks sold or consumed or of all goods, merchandise and commodities and services of any kind and description provided or sold within or through or out of the Permit Area plus all other income deriving from or in respect of the Permit Area; and

- (u) he shall pay to the Government any cost incurred by the Government plus an administrative overhead charge to be advised by the Government Representative if he fails to carry out any of his obligations or duties under this Agreement and the Government Representative executes such obligations or duties on his behalf.

12. Cleansing, Collection and Disposal of Refuse and Litter

- (a) The Permit Holder shall provide and keep in good and hygienic condition dustbins in such numbers and of such a type as shall be approved by the Government Representative and shall collect all refuse and litter therein.
- (b) The Permit Holder shall arrange at least once every day or at a frequency as prescribed by the Government Representative at any time and from time to time for the removal and disposal of all refuse and litter thus collected in the course of his Business. Such refuse and litter shall be collected in polyethylene bags, or in any other containers approved by the Government Representative and shall be properly disposed of at least once every day to such a refuse collection point inside or outside the Venue designated by the Government Representative or to such places as shall be specified by the Government Representative at any time and from time to time in such manner as approved or prescribed by the Government Representative. The Government Representative reserves the right to alter the designated refuse collection points and disposal method and the Permit Holder shall follow such direction by the Government

Representative and make necessary arrangement as approved by the Government Representative at his own cost.

- (c) The Permit Holder shall carry out cleansing and clearing of all grease traps in the Permit Area for which the Permit Holder is liable for, at least, on a daily basis and of all the drainage and sewerage pipes in the Permit Area for which the Permit Holder is liable for at frequent intervals to the Government Representative's reasonable satisfaction to prevent chokage and blockage of the installations. Where the Government Representative reasonably considers that hot or warm effluent can congeal and cause blockage within the drainage system, the Permit Holder shall forthwith on demand by the Government Representative undertake at his own expense either an emulsifying or a neutralizing effect by using such equipment or by employing such contractor as may be approved or prescribed by the Government Representative.
- (d) In the event of failure to comply with this clause, the Permit Holder shall pay the Government Representative on demand the costs incurred by the Government Representative if the removal and disposal of such refuse and litter; or the cleansing or clearing of any of the drains, sewers and grease traps choked or blocked is carried out by the Government Representative due to the act, default or negligence of the Permit Holder or any of his employees or agents.
- (e) The Permit Holder shall not place, or leave, or cause, or suffer, or permit to be placed or left in any part of the Venue (including but not limited to fire exits, common area, stairways, landings and passages of such buildings) any solid waste or any other similar materials. The Permit Holder shall arrange at his own cost proper and immediate disposal of the same at designated locations as approved by the Government authorities from time to time.
- (f) The Permit Holder shall deploy sufficient and adequate manpower to carry out continuous spot cleansing of the toilets as and when necessary to supplement regular services. All toilets should be kept clean at all times to the satisfaction of the Government Representative.

- (g) The Permit Holder shall maintain the toilets free from odour and dry on the ground at all times and shall mop dry all floor after cleansing.
- (h) The Permit Holder should intensify the cleansing services of the toilets as and when instructed by the Government Representative.

13. Monies or Valuables Found or Property Lost

All monies or other items of value found by the Permit Holder, his employees and agents in carrying out his Business in the Permit Area shall be handed to the Government Representative's management in the Venue as soon as possible and a written receipt obtained therefrom.

14. Permit Holder's Employees or Agents

- (a) The Permit Holder shall require all persons employed at the Permit Area to submit to such medical examinations at such places and times as may be prescribed by a registered medical practitioner and shall not employ or shall cease to employ at the Permit Area any person found by the medical practitioner to be likely to spread a communicable disease.
- (b) The Permit Holder shall ensure that his managerial or supervisory staff shall be in attendance at the Permit Area at all times when his staff are at work.
- (c) The Permit Holder shall be responsible for the good conduct of his employees or agents while they are in the Permit Area, and shall ensure that they will behave accordingly.
- (d) The Government Representative shall be entitled to demand on reasonable grounds, including but not limited to medical, health, security and disciplinary grounds, the removal or replacement of any of the Permit Holder's employees or agents.
- (e) The Government Representative and the Government shall in no circumstances be liable either to the Permit Holder or to his employees or agents in respect of any liabilities, losses or damages occasioned by such removal as stipulated in Clause 14(d) and the

Permit Holder shall fully indemnify the Government against any claim made by such employees or agents.

- (f) The Government Representative shall be entitled to refuse to admit to the Venue or any part thereof for the purpose of the Agreement any person employed by the Permit Holder, or by the Permit Holder's agents, whose admission will be, in the opinion of the Government Representative, undesirable.
- (g) Any removal demanded or refusal made under Clauses 14(d) and 14(f) shall not be construed as a breach of the Agreement by the Government Representative and the Permit Holder shall continue to carry out his obligations under the Agreement.
- (h) The Permit Holder shall provide a sufficient quantity of clean clothes with clear identifications of his Business and of a type approved by the Government Representative for the use of his employees at the Permit Area.
- (i) The Permit Holder shall provide lockers for the staff to store their clothing and personal effects and not to allow personal effects such as clothing, footwear, luggage, umbrellas and other articles to be stored or left in any room where food for sale for the purpose of the Light Refreshment Restaurant and Light Refreshment Business is stored.
- (j) The Permit Holder shall ensure that at all times when his employees are at work or on duty in the Permit Area they shall wear clothes in a clean and tidy manner.
- (k) The Permit Holder shall ensure that all persons employed by him in carrying out the Agreement shall keep to such parts of the Venue as are necessary for the due discharge of the Permit Holder's obligations under the Agreement.
- (l) The Permit Holder shall maintain a proper, current and accurate record of all his employees or agents employed for carrying out his Business. Such record shall include the name, Hong Kong Identity Card number, grade, age and photograph of each employee. The

Permit Holder shall produce such record for inspection by the Government Representative on request.

- (m) The Permit Holder shall not employ any person who is forbidden in the laws of the Hong Kong Special Administrative Region or not entitled for whatever reasons to undertake any employment in the Hong Kong Special Administrative Region in the execution of this Agreement or any other Government contract. If there is any breach of this clause by the Permit Holder, the Government Representative may, by notice in writing, terminate this Agreement and the Permit Holder is not entitled to claim any compensation. The Permit Holder shall be responsible for any expenses or loss that the Government Representative may incur or suffer due to the breach of this clause by himself.
- (n) Unless otherwise approved by the Government Representative, all workers and staff employed by the Permit Holder for the execution of this Agreement shall be local residents to be engaged in the Hong Kong Special Administrative Region. Any contravention of this clause shall be deemed as a material breach of the Agreement, which shall entitle the Government Representative to terminate the Agreement by giving fourteen (14) days' notice to the Permit Holder.
- (o) The Permit Holder shall be liable for all expenses necessarily incurred by the Government Representative as a result of the termination of this Agreement.
- (p) The Permit Holder shall not employ any person for operation of his Light Refreshment Restaurant and Light Refreshment Business at the Permit Area who has not been inoculated against typhoid and paratyphoid and inoculated and vaccinated against such other diseases as the Government Representative may direct.

15. Publicity and Advertisement

- (a) The Permit Holder shall not publish or use any advertising or other publicity materials or perform any act with an advertising nature in relation to his Business except with the prior written consent of the Government Representative.

- (b) Save and except where the Government Representative at its discretion may permit or require, the Permit Holder shall not exhibit or display, or cause, or permit, or suffer to be exhibited or displayed either inside or outside the Permit Area any advertisement or any other materials whatsoever (such as writings, signs, signboards or any other devices whether illuminated or not which may be visible from inside or outside the Permit Area or any part thereof) of any advertising nature.
- (c) Without prejudice to the generality of Clause 15(b), the Permit Holder shall not exhibit or display, or cause, or permit, or suffer to be exhibited or displayed either inside or outside the Permit Area any advertisement or any other materials whatsoever (such as writings, signs, signboards or any other devices whether illuminated or not which may be visible from inside or outside the Permit Area or any part thereof) of any advertising nature relating to any tobacco or tobacco-related products.

16. Notices to be Displayed or Circulated in the Venue

If the Permit Holder proposes to display or circulate any notices requiring his employees, agents or the public to comply with the rules and regulations of the Government Representative, the Government or other competent authority or for the purpose of the operation of his Business under the Agreement, he shall seek the prior written consent of the Government Representative and such consent can be withdrawn at any time at the discretion of the Government Representative. All notices displayed or circulated by the Permit Holder in the Venue shall be written in both English and Chinese.

17. Water Supply

- (a) The Permit Holder, if so permitted by the Government Representative, may use water supply which may be available at the Venue to operate his Business and shall pay all fees and charges in connection therewith.
- (b) If water supply is not available at the Permit Area, or permission to

use available supply is not granted or is withdrawn, the Permit Holder shall at his own expense install and provide such supply for his Business and pay all fees and charges in connection therewith.

- (c) All installation of tubing and piping, and all other water supply works, be it permanent or temporary, shall be approved by the Government Representative and the works shall be carried out by qualified personnel approved by and to the satisfaction of the Government Representative, and such installation shall thereupon become the property of the Government. The Permit Holder shall be responsible to maintain and repair such installation at his own expense as well as to remove the same should the Government Representative so direct.

18. Electricity Supply

- (a) The Permit Holder, if so permitted by the Government Representative, may consume electricity from supply point which is available at the Venue to operate his Business and shall pay all fees and charges in connection therewith. The maximum electricity loading available to the Light Refreshment Restaurant and Light Refreshment Kiosk is 63 AMP single phase respectively.
- (b) If electricity supply point is not available at the Permit Area, or permission to use available supply point is not granted or is withdrawn, the Permit Holder shall at his own expense install and provide his own source of electricity supply required for his Business and pay all fees and charges in connection therewith.
- (c) Any installation of wiring and lighting fittings, and all other electrical works, be it permanent or temporary, shall be approved by the Government Representative and the works shall be carried out by qualified electricians registered under the Electricity (Registration) Regulations (Cap. 406 sub. leg. (D)) and to the satisfaction of the Government Representative, and such installation shall thereupon become the property of the Government. The Permit Holder shall be responsible to maintain and repair such installation at his own expense as well as to remove the same should the Government Representative so direct.

19. Rights Reserved by Government Representative

- (a) The Government Representative reserves the right to suspend at its sole discretion the Permit Holder's Business by closing the Permit Area for a specified period of not more than seven (7) days at any one (1) time if the Government Representative is of the opinion that the Permit Holder is in breach of any of the terms and conditions of the Agreement and in such event the Permit Holder shall remain liable to pay the Monthly Permit Fee in full during such period of suspension.
- (b) The Government Representative reserves the right to close the Venue in whole or in part, including the Permit Area and/or to suspend the Business by reason of fire or storm or damage (not being the result of wilful default or misconduct or negligence of the Permit Holder, his employees or agents) or an act of God or repair or maintenance or building modification or for any other reasons at any time and for whatever period or periods during the Term. The Government shall not be liable for any loss suffered or expenses incurred whatsoever by the Permit Holder due to such closure or suspension.
- (c) In connection with Clause 19(b), if the demand of such closure or suspension of the Business by the Government Representative is due to repair or maintenance or building modification, the Government Representative will give the Permit Holder one (1) month's advance notice before the commencement date of such closure and/or suspension, if it is practicable in the circumstances.
- (d) If there shall be suspension of the Business as required under Clause 19(b), the Monthly Permit Fee shall be adjusted according to Clause 7 hereof.
- (e) Notwithstanding Clause 3 hereof, the Government Representative may permit any Person or organisation to provide in the Venue by way of sale or otherwise any refreshments or commodities. Irrespective of whether or not the Business of the Permit Holder might be affected by such arrangement, the Government

Representative and the Government shall not be liable to pay any compensation whatsoever to the Permit Holder and shall not be required to abate the Monthly Permit Fee or any part thereof.

- (f) For the avoidance of doubt, nothing expressed or implied in the Agreement shall be regarded as in any way negating, prejudicing or otherwise restricting the right of the Government Representative to authorize any Person or organisation to bring into the Venue or distribute freely therein any refreshments or commodities for consumption or for use whatsoever. The Permit Holder is not entitled to claim for any compensation or prohibition for whatsoever causes resulting from the grant of the said permissions and authorizations. The Permit Holder shall continue to carry on his Business on any day covered by such permission if he is not required to suspend his Business.
- (g) Notwithstanding Clause 3 hereof, the Government Representative may, by giving not less than seven (7) days' notice to the Permit Holder, hold or permit any Person or organisation to hold any function in the Venue. Where the Government Representative considers it necessary to do so, it may require the Permit Holder to suspend the whole or part of his Business temporarily during the time when such functions are being held in the Venue. The Permit Holder is not entitled to claim for any compensation whatsoever resulting from the grant of the said permissions and the holding of the functions. If the Permit Holder suspends his Business whether in whole or in part as demanded by the Government Representative under this clause, the Monthly Permit Fee shall abate on a pro rata basis depending on the length and extent of such suspension of the Business which shall be determined by the Government Representative. The Permit Holder shall continue to carry on his Business on any day covered by such permission if he is not required to suspend his Business.
- (h) Notwithstanding Clause 3 hereof, the Government Representative reserves the right to provide or allow any Person or contractor to provide drinking fountain, catering services and/or vending machine service within any other areas of the Venue during the Term of the Agreement. Irrespective of whether or not the Business of the Permit

Holder might be affected by such arrangement, the Government shall not be liable to pay any compensation whatsoever to the Permit Holder and shall not be required to abate the Monthly Permit Fee or any part thereof.

- (i) Notwithstanding anything to the contrary provided herein, the Government Representative shall be entitled to no more than twenty (20) days in any one period of twelve (12) months to set aside the Venue or any part thereof for the purpose of holding of any rowing, boating or other training or activities whatsoever by the Government Representative himself or any Person or organization other than the Permit Holder as the Government Representative may so authorized, in which event:

(i) the Permit Holder or the Person or organization so authorized may, but shall not be obliged to, hire from the Permit Holder any row boats, pedal wheel boats, model boats and other approved hiring facilities which may be required; and

(ii) the Permit Holder shall not hire out any Boats and other approved hiring facilities to any other Person whatsoever on the day when such training or activities take place.

Provided always that the Government Representative shall inform the Permit Holder of any such activities by notice in writing not less than seven (7) days in advance.

- (j) The Government Representative reserves the right to empty water from the reservoir temporarily for general cleansing purposes or for necessary repair. No deduction of Permit Fee shall be made if the closure necessitated thereby does not exceed a period of seven (7) days.
- (k) The Government Representative makes no representation and gives no warranty or assurance as to the condition, safety or suitability of the Venue for any purpose whatsoever nor in any way guarantees the continued use or operation of the Permit Area as a public pleasure ground within the meaning of the Pleasure Grounds Regulation, Cap. 132 Subsidiary Legislation or its level of

utilization. Without prejudice to the generality of the foregoing, the Government Representative may at any time and from time to time at its sole discretion close or restrict the use of or the access of the public to the whole or any part of the Venue or forbid the entry of any person to the same for any period or periods as it may deem necessary without incurring any liability whatsoever to the Permit Holder in respect of any disturbance to or reduction in or loss of business consequent thereon, in which event the Permit Holder shall not be entitled to any claim whatsoever for compensation and all fees, charges and other payment whatsoever payable by the Permit Holder to the Government Representative hereunder shall remain payable in full in respect of such period or periods.

20. Sale and Hire of Commodities

- (a) The Permit Holder shall notify the Government Representative of the latest price list whenever the Government Representative so demands.
- (b) The Permit Holder shall abide by any directions as to the quality of the commodities sold or offered for sale at the Permit Area as may be given by the Hong Kong Consumer Council.
- (c) The Permit Holder shall provide to customers upon request receipts for commodities sold or services hired specifying the commodities or types of boats and the respective price as appropriate.

21. Display of Commodity Prices

The Permit Holder shall prominently display at all times the prices of commodities for sale and rate of hiring of Boats in respect of his Business at the Permit Area. The displays shall be in both Chinese and English and put up in such form, manner and at such locations as shall be approved or prescribed by the Government Representative.

22. Erection of Structure

- (a) The Permit Holder shall not allow or permit any structure to be erected in or on the Permit Area and its immediate vicinity except

those stipulated in Clause 21 hereof and apart from one (1) signboard each bearing the words “BOAT HIRING OFFICE”, “LIGHT REFRESHMENT RESTAURANT”, “LIGHT REFRESHMENT KIOSK” respectively for the Business in both English and Chinese.

- (b) The size and location of the signboards shall be those approved or prescribed by the Government Representative in writing.

23. Watchman

- (a) The Permit Holder shall not allow any person to remain in the Permit Area overnight without the permission in writing from the Government Representative. Such permission to remain a person in the Permit Area overnight shall only be given to enable the Permit Holder to post a watchman to look after the contents of the Permit Area.
- (b) The Permit Holder shall ensure that the watchman should possess a valid security personnel permit issued under the Security and Guarding Services Ordinance (Cap. 460) and submit to the Government Representative for approval the name and Hong Kong Identity Card number of such watchman.
- (c) The Permit Holder shall immediately remove such person from the Permit Area if the Government Representative notifies the Permit Holder in writing of the withdrawal of its approval for such person to stay overnight in the Permit Area.

24. Use of Fuel

- (a) The Permit Holder shall heat or cook food or boil water by electricity or liquefied petroleum gas only.
- (b) The Permit Holder shall not carry out or permit to be carried out any cooking of food at the Waiting Area and not to carry out cooking, heating or re-heating of food in areas without obtaining the prior written approval of the Government Representative.

25. Store of Dangerous Goods and Prohibited Goods

Except a reasonable quantity to be stored at the Permit Area required for the operation of the Business, the Permit Holder shall not keep, store or cause, permit or suffer to be kept or stored in the Permit Area any dangerous or prohibited goods or liquefied petroleum gas or any other types of fuel within the meaning of the Dangerous Goods Ordinance (Cap. 295) or any arms, ammunition, explosives or combustible substances.

26. Fire Fighting Equipment

The Permit Holder shall provide and maintain in proper and serviceable condition fire fighting equipment to the satisfaction of the Government Representative and comply with any directions issued by the Buildings Department or the Fire Services Department in connection with the Permit Area.

27. Discharge of Waste Water

The Permit Holder shall ensure waste water that comes out from the Permit Area is free of grease and shall not cause, suffer or permit to be caused the waste water discharging onto areas surrounding the Permit Area.

28. Sale of Alcoholic Liquor

- (a) The Permit Holder shall not sell alcoholic liquor in the Permit Area without first obtaining the written permission of the Government Representative.
- (b) The Government Representative shall take into account all relevant factors in considering whether to grant the permission referred to in Clause 28(a) to the Permit Holder if the latter applies to the Government Representative for such permission. The Government Representative reserves the right to withdraw any permission granted and shall not be required to provide any reasons to the Permit Holder for such withdrawal.
- (c) The Permit Holder shall obtain the licence as is required under the Dutiable Commodities Ordinance (Cap. 109) if the sale of alcoholic

liquor is for consumption at the Permit Area.

29. Arrangement During Epidemic Illness

In the event of illness of any epidemic nature breaking out, the Permit Holder shall comply with all such orders, arrangements or regulations as may be issued by the Government with a view to stamping out the same. The Permit Holder shall comply with any instructions issued by the Government regarding measures to be adopted to prevent or control diseases of any kind.

30. Government Premises, Property, Machinery and Equipment

- (a) When the Government premises, property, machinery or equipment is provided for the Permit Holder under the Agreement (inclusive of those listed in the Fourth Schedules A and B), the Permit Holder shall keep and maintain the same in good, clean and serviceable condition (fair wear and tear excepted), and shall be responsible for the due and immediate return of all such premises, property, machinery and equipment in good repair, clean and serviceable condition (fair wear and tear excepted) at any time upon request by the Government Representative and/or upon the expiry or termination of the Agreement.
- (b) The Permit Holder shall not make any alteration or addition to the premises, property, machinery and equipment provided by the Government therein without the prior permission in writing by the Government Representative and shall not carry out the repairs to the same without obtaining the prior approval of the Government Representative. If such approval is obtained, the repair works shall be carried out by qualified Person approved by and to a standard acceptable to the Government Representative.
- (c) The Permit Holder shall be liable to the Government for any damage or loss to such premises, property, machinery and equipment provided by the Government. If any such premises, property, machinery or equipment is found damaged or lost, as the case may be, in whatsoever scale and from whatsoever cause while in the occupancy or control of the Permit Holder, the Permit Holder shall

pay the cost for all repair or replacement of the same plus a sum to be advised by the Government Representative as administrative overhead charges.

- (d) All premises, property, machinery and equipment so provided for the Permit Holder under the Agreement, shall remain the property of the Government, and the Government Representative reserves the right to take stock checking of the same at any time and the Permit Holder shall provide every assistance to the Government Representative for this purpose.
- (e) The Permit Holder shall accept the Permit Area and the Government's provisions of property, machinery or equipment under the Agreement (inclusive of those listed in the Fourth Schedules A and B) in the state and condition in which occupancy is given.

31. Access Granted to the Permit Holder

- (a) The Government Representative shall grant access of the Venue or any part thereof to the Permit Holder as may be necessary for him, his employees or agents to perform his obligations under the Agreement, provided that the Government Representative shall be entitled to close the Venue or any part thereof or to prohibit any vehicular access to the Venue at any time and for any period if the Government Representative considers it prudent and expedient to do so. Such closure should not be deemed to be a breach of the Agreement by the Government Representative.
- (b) Upon such closure or prohibition of access or on demand of the Government Representative, the Permit Holder and his employees and agents shall forthwith suspend his Business, remove the plant, equipment, materials and vehicles under the control of the Permit Holder from the Venue.

32. Inconvenience or Annoyance Caused at the Venue

- (a) The Permit Holder shall ensure that his employees or agents shall perform their duties in an orderly manner and in as quiet a manner as may reasonably be practicable having regard to the nature of the

duties being performed by them.

- (b) The Permit Holder shall use his best endeavors to avoid causing nuisance or annoyance to the users using the Venue or to the Government's staff or agents working there while carrying out his Business. The Government Representative shall be, without prejudice to any rights it has under the Agreement and without releasing or discharging the Permit Holder of his obligations hereunder and without compensation whatsoever to the Permit Holder, entitled to suspend the Business or by whatever means the Government Representative may consider suitable so as to stop the Permit Holder from causing further nuisance to the users of the Venue and the Government's staff or agents working there.
- (c) The Permit Holder shall not place or leave, or cause, or suffer, or permit to be placed or left any of his trade equipment, stores, provisions, furniture, fixtures, fittings, chattels or other things whatsoever at any places within the Venue other than the Permit Area or otherwise howsoever encumber or encroach such places and shall forthwith remove the same to a place designated by the Government Representative if the Government Representative in its opinion considers that they may cause encumbrance or encroachment. In the event of any breach of this clause and without prejudice to any other rights and remedies which the Government Representative has or may have under the Agreement, the Government Representative shall be entitled to take all such steps as may be necessary to forthwith remove any such encumbrances or encroachments thereby constituted and without notice to the Permit Holder to seize and dispose of any such property in such manner as the Government Representative may see fit without any liability whether towards the Permit Holder or any other Person and the Permit Holder shall pay the Government on demand all the costs in relation to such removal and/or disposal which are incurred by the Government.

33. Inspection and Rejection

- (a) The Business carried on by the Permit Holder shall be subject to inspection by the Government Representative at any time.

- (b) Without prejudice to any other rights provided under the Agreement, the Government Representative may reject any action undertaken by the Permit Holder or result of such action which does not strictly conform to the terms and conditions of the Agreement.
- (c) Within twenty-four (24) hours (or such longer time as may be notified by the Government) of being notified in writing of the rejection of any action undertaken by the Permit Holder or result of such action, the Permit Holder shall take necessary action to rectify such rejected action or result of action to the satisfaction of the Government Representative.
- (d) If the Permit Holder shall fail to rectify such rejected action or result of action, the Government Representative may without prejudice to any other rights and remedies available to the Government carry out and complete such rectification by its own staff or by its agents. All costs and expenses whatsoever which may be incurred by the Government thereof shall be recoverable in full from the Permit Holder forthwith on demand. The normal working hours for the staff of the Government are, with the exception of General Holiday, from 9:30 a.m. to 4:30 p.m. from Monday to Friday. If such rectification is carried out by the staff of the Government outside these normal working hours, the Permit Holder shall be responsible for the overtime remuneration, subsistence allowances and traveling expenses of such staff.

34. Permit Holder's Act, Default, etc.

- (a) Any act, default, negligence or omission of any employee, agent or invitee of the Permit Holder shall be deemed to be the act, default, negligence or omission of the Permit Holder.
- (b) It shall be regarded as a default, if the Permit Holder –
 - (i) shall have abandoned the Agreement; or
 - (ii) shall persistently or wilfully neglect to carry out his obligations under the Agreement; or

- (iii) shall fail to carry out all or any of the rectification as stipulated in Clause 33(c) hereof within the time specified.
- (c) Without prejudice to any other rights provided for under the Agreement, the Government is entitled to claim indemnity from the Permit Holder against any and all losses, claims, damages, costs, charges, expenses, liabilities, demands, proceedings and actions which the Government may sustain or incur or which may be brought or established against it as a result of the Permit Holder's default.
- (d) Notwithstanding the above provision, the Government Representative may at its own discretion terminate the Agreement in accordance with Clause 40 hereof as a result of the Permit Holder's default.

35. Accident to Permit Holder's Employees

- (a) The Government, its employees and agents shall not be under any liability whatsoever for or in respect of any injury to or death of any of the Permit Holder's employees or agents save and except such injury or death caused by the negligence of the Government or its employees or agents. The Permit Holder shall indemnify the Government, its employees and agents against all losses, claims, damages, costs, charges, expenses, liabilities, demands, proceedings and actions whatsoever in respect of any such injury or death for which the Government and its employees and agents are not liable under this clause.
- (b) The Permit Holder shall effect and keep in force at his own expense a policy of insurance against all liability to pay damages or compensation as aforesaid in respect of all staff and other persons, other than the Government employees who may be employed by the Permit Holder on any work done in pursuance of the Agreement with an insurance company authorized by the Insurance Companies Ordinance (Cap. 41) and on such terms and conditions to be approved by the Government Representative, and shall, as and when required, deposit with the Government Representative for safe

keeping a copy of such policy of insurance together with the receipt for payment of the current premiums.

- (c) In the event of any staff or other persons employed by the Permit Holder on any work done in pursuance of the Agreement suffering any personal injury or death, the Permit Holder shall within forty-eight (48) hours notify the Government Representative in writing and whether there be a claim for a compensation or not, the Permit Holder shall, as soon as it is practicable thereafter, give notice in writing of such personal injury or death to the Commissioner for Labour and the insurer.

36. Liability and Indemnity

- (a) The Permit Holder shall indemnify the Government and keep the Government fully and effectively indemnified against all losses, claims, damages, costs, charges, expenses, liabilities, demands, proceedings and actions which the Government may sustain or incur or which may be brought or established against it by any Person and which in any cases arise out of or in relation to or by reasons of —
 - (i) the negligence, recklessness or wilful misconduct of the Permit Holder, his employees or agents; or
 - (ii) the breach or the non-performance or non-observance of any of the warranties and undertakings, obligations or conditions by the Permit Holder, his employees or agents; or
 - (iii) any defaults, unauthorized acts or omissions of the Permit Holder, his employees or agents; or
 - (iv) the non-compliance with any applicable laws and any requirements or regulations of any Government authorities or agencies in connection with the performance of the obligations under this Agreement by the Permit Holder, his employees or agents; or
 - (v) any loss or damage sustained by or any injury to or death of any third party which is partially or jointly in consequence of

any negligence, omission, default of the Government or its employees or any agent under statute and under common law as long as such loss or damage sustained by or any injury to or death of such third party is partially or jointly attributable to the Permit Holder or his employees or agents engaged by the Permit Holder (if any) in the manner as described in (i) to (iv) above.

- (b) The indemnities, payment and compensation given in pursuance of the Agreement by the Permit Holder shall not be affected or reduced by reason of any failure or omission of the Government Representative in enforcing any of the terms and conditions of the Agreement, or in supervising or controlling the Permit Holder's operation or method of working, or in detecting or preventing or remedying any defective work carried out by the Permit Holder, his employees or agents.

37. Public Liability Insurance

- (a) The Permit Holder shall effect, take out, maintain and renew upon expiry at his own expense a policy of insurance (including public liability) for the benefit of and in the joint names of the Permit Holder and the Government of the Hong Kong Special Administrative Region in the sum of not less than Ten Million Hong Kong Dollars (HK\$10,000,000) for any one (1) incident and for an unlimited number of claims arising during the Term with an insurance company authorized by the Insurance Companies Ordinance (Cap. 41) on such terms and conditions to be approved by the Government Representative. There shall be no limit to the number of claims during the period of insurance.
- (b) The policy of insurance shall cover full liability to pay damages or compensation as a result of the damage to properties, death of or injury to or illness suffered by any person arising out of any act, negligence or default of the Permit Holder, or the Government or their employees and agents. The policy of insurance shall also indemnify all sums which the Permit Holder and the Government shall become legally liable to pay as compensation for bodily injury due to any food, drinks and/or commodities sold / supplied by the

Permit Holder at the Venue.

- (c) The Permit Holder shall keep the aforesaid policy of insurance in force during the continuance of the Agreement and shall forthwith deposit with the Government Representative for safe keeping a copy of such policy of insurance together with the receipt for payment of the current premiums.
- (d) If the terms of the policy of insurance taken out by the Permit Holder require the insured parties to bear any excess amount in the event of claims, the Permit Holder shall be personally and solely responsible for the payment of such excess amount and shall indemnify the Government for such payment. Under no circumstances whatsoever shall the Government be responsible for the premium payable under the public liability insurance policy or the premium payable for the renewal thereof.
- (e) The policy of insurance shall include a cross liability clause.
- (f) The Permit Holder is responsible to lodge all claims with the insurance company and shall deal with the said company upon receipt from the Government Representative or otherwise of a report on any injury, death, loss or damage.
- (g) The Permit Holder shall conform to the terms and conditions of the public liability insurance policy and all reasonable requirements of the insurers in connection with the settlement of claims, the recovery of losses and the prevention of accidents. The Permit Holder shall not do or permit or suffer to be done any act or omission whereby the public liability insurance policy shall be rendered void or voidable, or which would otherwise amount to breach of the public liability insurance policy. The Permit Holder shall bear the economic consequences of, and indemnify the Government in full from and against any loss and liability which may arise from any failure of the Permit Holder to observe and comply with this clause.

38. Failure to Insure

If the Permit Holder shall fail to effect or to keep in force the policy of insurance referred to in Clauses 35 and 37 or any other policy of insurance which it may be required to effect under the terms and conditions of the Agreement, the Government Representative may effect and keep in force any such policy of insurance and pay such premium or premiums thereof as may be necessary for that purpose and may from time to time deduct the amount so paid from the Security Deposit in accordance with Clause 8 hereof or may recover the same as a debt due from the Permit Holder.

39. Corrupt Gifts

- (a) If the Permit Holder or any of the Permit Holder's employees or Permit Holder's agents commits an offence under the Prevention of Bribery Ordinance (Cap. 201) or under any law of a similar nature in relation to the Agreement or any other Government contracts, the Government Representative may, on behalf of the Government, summarily terminate the Agreement, without entitling the Permit Holder to any compensation therefor.
- (b) The Permit Holder shall be liable for all expenses necessarily incurred by the Government as a result of the termination of the Agreement under this clause.
- (c) The Permit Holder shall not, whether by himself or by any person employed by him to provide the services, solicit or accept any gratuity, tip or any other form of money taking or reward, collection, or charge for any part of the services other than charges properly approved in writing by the Government Representative under the Agreement. The Permit Holder shall prohibit his employees and agents who are involved in this Agreement from offering, soliciting or accepting any advantage as defined in the Prevention of Bribery Ordinance (Cap. 201) when conducting business in connection with this Agreement.
- (d) The Permit Holder shall within fourteen (14) days after the commencement of the Agreement draw up and submit a staff code of conduct to the Government Representative including, among other probity issues, a statement explicitly prohibiting any person employed by him to provide the services from soliciting or accepting any form of advantages in discharging his duties under the Agreement. The Permit Holder shall ensure that any person employed by him to provide the services is well aware of the

prohibited acts explicitly stated in Clause 39(c) above and of the staff code of conduct. The code of conduct should form part of the employment contract to ensure acknowledgement and compliance by the employees.

40. Termination

- (a) Without prejudice to any right or action or remedy which shall have accrued or shall accrue thereafter to the Government Representative, the Government Representative may at any time by notice summarily terminate the Agreement without entitling the Permit Holder to compensation in any of the following events –
- (i) if the Permit Holder fails or neglects to observe or perform any of the terms and conditions of the Agreement or fails to pay any of the sums payable by the Permit Holder under the Agreement or in the case of a breach capable of being remedied, will have failed within fourteen (14) days or such longer period as the Government Representative may allow after the receipt of a notice in writing from the Government Representative so to do to remedy the breach (such notice shall contain a warning of the Government Representative's intention to terminate the Agreement); or
 - (ii) if the Permit Holder goes into liquidation, or is at any time adjudged bankrupt, or is having a receiving order or orders for administration of his estate made against him, or takes any proceedings for liquidation or composition under the Bankruptcy Ordinance (Cap. 6) for the time being in force, or becomes insolvent, or makes a proposal for a composition or a scheme of arrangement or makes any conveyance or assignment of his effects for the benefit of his creditors or purports so to do, or suffers any execution to be levied on his goods and assets in the Permit Area, or a petition is filed for the bankruptcy or winding up of his Business otherwise than for the purpose of a reconstruction or amalgamation previously approved by the Government Representative in writing; or

- (iii) if the Permit Holder, being a company, passes a resolution, or the court makes an order, or a receiver or manager is appointed on behalf of the debenture holders, or circumstances which entitle the court or debenture holders to appoint a receiver or manager have arisen, for the liquidation of the Permit Holder's assets; or
 - (iv) if the Permit Holder assigns or purports to assign all or any part of the burden or benefits of the Agreement without the prior written consent of the Government Representative.
 - (b) Notwithstanding any provision to the contrary, either party may terminate the Agreement by serving to the other party a six (6) months' prior notice in writing specifying the date of termination provided that the said date of termination shall be a date at least eighteen (18) months after the commencement of the Agreement.
 - (c) If the Government Representative shall at any time be prevented from performing the Agreement by force majeure, then the Agreement shall terminate immediately but without prejudice to the rights and remedies of either party against the other in respect of any antecedent claim or breach of any of the terms and conditions of the Agreement.
 - (d) For the purpose of Clause 40(c), "force majeure" means acts of God, strikes, lockouts, acts of war, civil disorders, governmental laws, orders or regulations or other similar or different events or contingencies beyond the reasonable control of the respective parties. For these purposes an event shall not be deemed to be within the control of the Government Representative on the grounds that the Government Representative could have prevented that event by acceding to any unreasonable demands of an authority, corporation, trade union, association or person.

41. Effect of Termination

- (a) Upon termination of the Agreement –

- (i) the Permit Holder shall immediately deliver up vacant possession of the Permit Area including the appliances, furniture, fixtures and fittings provided by the Government Representative or the Government therein in good repair (fair wear and tear excepted) and in clean and hygienic condition. Provided always that where the Permit Holder has made any alterations or installed any fixtures or additions to the Permit Area with or without the Government Representative's consent, the Government Representative may at its discretion require the Permit Holder to reinstate or remove at the Permit Holder's own expense such alterations, fixtures, fittings or additions or such part or portion thereof as the Government Representative may require and to make good and repair in a proper and workmanlike manner any damage to the Permit Area and to the fixtures and installations thereof before delivering up the Permit Area to the Government Representative;
- (ii) the Permit Holder shall at his own expense forthwith retreat all his employees or agents and remove from the Permit Area all his fixtures, fittings, structures, materials, machinery, equipment, plant and all other properties which the Government Representative does not desire to take over. The Permit Holder shall at his own expense make good any damage to the Government premises, property, machinery and equipment which are caused by such retreat or removal;
- (iii) the Permit Holder shall return all Government premises, property, machinery and equipment provided by the Government under the Agreement in the manner as stipulated in Clause 30 hereof; and
- (iv) if the Permit Holder shall fail to comply with Clause 41(a)(ii), the Government Representative may forthwith enter the Permit Area to remove any person therein, or to remove any fixtures and fittings so installed or erected, or any property, materials, machinery and equipment found therein and to effect the necessary repair and cleansing work so as to keep the Permit Area in a good repair, clean and serviceable

condition. The Government Representative reserves the right to take over or to dispose of in whatsoever manner it deems appropriate and without any liability and compensation whether towards the Permit Holder or any other party any fixtures and fittings so installed or erected and any chattels not collected or removed by the Permit Holder upon the termination of the Agreement. All costs, losses, damages or expenses incurred by the Government as a direct or indirect result of the breach of the Agreement under this clause shall be recoverable as a debt due from the Permit Holder.

- (b) Any termination of the Agreement howsoever occasioned shall not affect any accrued rights or liabilities of either party nor shall it affect the coming into force or the continuance in force of any provision hereof which is expressly or by implication intended to come into or continue in force on or after such termination.

42. Recovery of Sums Due

Whenever under the Agreement any sum of money (including but not limited to rates and Government rent payable in respect of the Permit Area) shall be recoverable from or payable by the Permit Holder, to the Government (but the Permit Holder has failed to pay the same by the due date), the Government Representative is entitled to deduct the same from any sum then due or which at any time thereafter may become due to the Permit Holder under this or any other agreement or agreements with the Government or from the Security Deposit in cash or by making a call on the banker's guarantee in accordance with Clause 8 hereof forthwith without notice.

43. Jurisdiction

The Agreement shall be governed by and construed according to the laws of the Hong Kong Special Administrative Region and the parties hereto irrevocably submit themselves to the exclusive jurisdiction of the courts of the Hong Kong Special Administrative Region.

44. Licence, Permit and/or Certificate

- (a) The Agreement does not confer exemption from any licensing requirements pertaining to the Permit Holder's Business.
- (b) The Permit Holder shall apply to the appropriate authorities to obtain or renew, as the case may be, all licences, permits and/or certificates required by the laws of the Hong Kong Special Administrative Region for the operation of his Business. The Permit Holder shall make no claim of any kind whatsoever against the Government Representative in the event of the Permit Holder's failure or inability for any reason to obtain or renew any such licences, permits and/or certificates.
- (c) It will be unlawful for the Permit Holder to operate his Business without the licences, permits and/or certificates as required by the laws of the Hong Kong Special Administrative Region, notwithstanding the granting of the Permit by the Government Representative. The Permit Holder shall not provide any service or for sale of any commodities for which any licence, permit and/or certificate is so required by law without first obtaining such licences, permits and/or certificates. The Permit Holder shall assume full responsibility for ensuring that those licenses, permits, and/or certificates shall remain in full force and effect as long as the Agreement remains in force.
- (d) Since it will necessarily take time for the relevant authorities to consider and decide on an application for the requisite licence, permit and/or certificate, the Permit Holder agrees and accepts that there will be no abatement or reduction of the Monthly Permit Fee on the grounds that the Permit Holder cannot conduct his Business pending the consideration of his applications and issuance or renewal of the relevant licences, permits and/or certificates. For avoidance of doubt, the non-issuance of the relevant licences, permits and /or certificates by relevant authority does not constitute any grounds for the abatement of the Monthly Permit Fee.
- (e) The Permit Holder shall observe and comply with the conditions of any licence, permit and/or certificate issued to him in relation to the performance of the Agreement.

45. Applicability of Public Health and Municipal Services Ordinance

The Agreement is subject to the provisions of the Public Health and Municipal Services Ordinance (Cap. 132), and of all regulations made thereunder, which may be applicable to the Venue, the Permit Area and to the Business. For activities relevant to licensing requirements regulated by the Director of Food and Environmental Hygiene, the Permit Holder shall visit the following Food and Environmental Hygiene Department's website for more information –

http://www.fehd.gov.hk/english/licensing/Guide_on_Types_of_Licences_Required.html

46. Compliance with Law and Government Requirements

- (a) The Permit Holder shall observe and comply with all applicable laws of the Hong Kong Special Administrative Region and requirements or regulations imposed from time to time by the relevant authorities in connection with the performance of his obligations under the Agreement.
- (b) The Permit Holder shall observe and comply with the Antiquities and Monuments Ordinance (Cap. 53) and make his best effort to ensure that his employees, agents and invitees comply with the ordinance. In the event of any demolition, removal, obstruction, defacement or interference with the Monuments by the Permit Holder, his employees, agents or invitees in the course of, in connection with or incidental to the Business, the Permit Holder shall-
- (i) notify the Government Representative and Director of Water Supplies in writing at the earliest opportunity and in any event within twenty-four (24) hours;
 - (ii) apply to the Secretary for Development for a permit under section 6 of Cap. 53 through the Government Representative with fourteen (14) days; and
 - (iii) restore the Monuments to their original state and condition at the Permit Holder's expense to the satisfaction of Southern District Leisure Services Office and Antiquities and

Monument Office of the Government and Water Supplies Department within a reasonable time.

- (c) Should the Permit Holder fails to take any step in Clause 46(b)(i) to (iii), the Government Representative may cause the restoration of the Monuments to be done and recover all monies incurred or expended from the Permit Holder under Clause 42 or otherwise as a civil debt due from the Permit Holder.

47. Service of Notice

- (a) Any notice to be given herein shall be in writing and shall be sent to the address of the recipient set out in the Agreement or to such other address as either party shall notify the other in writing. Notice may be delivered personally or by post, by courier or facsimile.
- (b) Any notice shall be deemed given –
 - (i) when left at the address of the recipient if delivered by hand during normal business hours; or
 - (ii) one (1) working day after despatch by post; or
 - (iii) when successfully despatched by facsimile.

48. Waiver of Remedies

- (a) No forbearance, delay or indulgence by either party in enforcing the provisions of the Agreement shall prejudice or restrict the rights of that party. Nor shall any waiver of its rights operate as a waiver of any subsequent breach and no right, power or remedy herein conferred upon or reserved for either party is exclusive of any other right, power or remedy available to that party and each such right, power, or remedy shall be cumulative.
- (b) Acceptance of any payment by the Government Representative shall not be deemed to operate as a waiver by the Government of any right to proceed against the Permit Holder in respect of any breach, non-observance or non-performance by the Permit Holder of any of the terms and conditions of this Agreement on the Permit Holder's part to be observed and performed.

49. Severability

- (a) In the event that any provisions of the Agreement or any part of any such provisions shall at any time be adjudged to be invalid, unlawful, illegal or otherwise howsoever unenforceable under any applicable laws of the Hong Kong Special Administrative Region, such provisions or such part of such provisions, as the case may be, to but only to the extent required by such laws, shall be severed from the Agreement and rendered ineffective so far as possible without modifying the remaining provisions hereof.
- (b) If at any time any one or more provisions hereof shall be adjudged to be invalid or illegal in any respect under any applicable laws of the Hong Kong Special Administrative Region, the validity, legality or enforceability of the remaining provisions hereof shall not in any way be thereby impaired or affected.
- (c) Where, however, the provisions or any such applicable laws of the Hong Kong Special Administrative Region may be waived, they are hereby waived by the parties hereto to the full extent permitted by such laws to the end that the Agreement shall be valid, binding and enforceable in accordance with its terms and conditions.

50. Relationship of the Parties

- (a) Nothing in the Agreement shall be construed as in any way constituting a partnership between the parties.
- (b) Neither party shall without the prior approval in writing of the other commit that other party to any obligation other than those prescribed in the Agreement.

51. Mediation

The parties hereto agree that any dispute or claim arising out of or in connection with this Agreement ('the Dispute') shall be referred to mediation prior to commencement of litigation. In default of Agreement, the Dispute shall be referred to mediation at the Hong Kong International

Arbitration Centre in accordance with its Mediation Rules. In case the Dispute cannot be resolved by mediation, the Dispute shall be referred to, and finally settled by, arbitration in accordance with and subject to the provisions of the Arbitration Ordinance (Cap. 609).

52. Entire Agreement

The Agreement embodies the entire understanding of the parties and supersedes all prior agreements, arrangements and undertakings between the parties and constitutes the entire Agreement between the parties relating to the subject matter thereof. No addition to or modification of any provision of the Agreement shall be binding upon the parties unless made by a written instrument signed by a duly authorized representative of each of the parties.

53. Exclusion

The parties hereby declare that nothing in this Agreement confers or purports to confer on any third party any benefit or any right to enforce any term of this Agreement pursuant to the Contracts (Right of Third Parties) Ordinance (Cap. 623).

SCHEDULES**First Schedule****Monthly Permit Fee**

- A. Subject to Paragraph B below, the Permit Holder shall pay to the Government in advance a Monthly Permit Fee as regards the grant of a Permit by the Government Representative to conduct the Light Refreshment Restaurant, Light Refreshment and Boat Hiring Business on the 15th day of each and every month without any reduction throughout the Term at the following rate –

Business	Monthly Permit Fee (in Hong Kong dollars)
Light Refreshment Restaurant and Light Refreshment	(i) Light Refreshment Restaurant: HK\$ _____ (in figures)
	(ii) Light Refreshment Kiosk: HK\$ _____ (in figures)
Boat Hiring	(iii) Boat Hiring Office: HK\$ _____ (in figures)
	(iv) Boat Shed: HK\$ _____ (in figures)
	(v) Waiting Area: HK\$ _____ (in figures)
	(i) + (ii) + (iii) + (iv) + (v) = HK\$ _____ (in figures)

- B. The Monthly Permit Fee does not include rates, Government rent and taxes payable in respect of the Permit Area and the Permit Holder's Light Refreshment Restaurant, Light Refreshment and Boat Hiring Business. The first payment of the Monthly Permit Fee is to be made not later than seven (7) days before the commencement of the Term or at such time as shall be directed by the Government Representative. When payment of the Monthly Permit Fee of any month is overdue, the Permit Holder shall pay to the Government a surcharge on that outstanding Monthly Permit Fee at an interest rate equivalent to the average of the best lending rate of the three note-issuing banks in Hong Kong plus 2% per annum. Such interest shall be calculated and payable from the day on which such payment falls due.

Name of Service Provider : _____ Date : _____

Name of Authorized Representative : _____

Signature of Service Provider
or Authorized Representative* : _____

(with Service Provider's chop, if applicable)

*Delete as appropriate

SCHEDULES**Second Schedule A****List of commodities recommended for sale at the Light Refreshment Restaurant and Light Refreshment Kiosk****Description of commodities**

- (a) Pre-packed soft drinks
 - (b) Ice cream and other frozen confections (The sale and/or manufacture of these items is subject to the grant to the Permit Holder of an appropriate licence from the Food and Environmental Hygiene Department)
 - (c) Pre-packed distilled and mineral water
 - (d) Chinese light refreshments
 - (e) Cakes
 - (f) Pastries
 - (g) Preserved foodstuffs
 - (h) Bread and biscuits
 - (i) Sweets
 - (j) Uncut fruit
 - (k) One of the groups of food items as stipulated in the Second Schedule B
- (From licensed food factories or other lawful sources and in original wrappers)

Notes :

- (1) All items for sale and their respective prices shall be prominently displayed at the Permit Area.
- (2) A Service Provider may offer for sale any other commodity, which is compatible with the licensing requirement relating to the Light Refreshment Restaurant and Light Refreshment Business.
- (3) It is not the intention of the Government Representative to exercise control over the prices of commodities for sale at the Permit Area.

SCHEDULES

Second Schedule B

List of food items to be sold at the Light Refreshment Restaurant

Licensed light refreshment restaurants may only prepare and sell one of the following groups of food items for consumption on the Light Refreshment Restaurant -

Group A

- (1) Noodles / vermicelli in soup with meat, offal, fish or sea food;
- (2) Wantun and dumplings in soup (also known as shui kau);
- (3) Boiled vegetables;
- (4) Tea, coffee, cocoa, any non-alcoholic drink or beverage made by adding water to prepared liquid or powder, and
- (5) Five self-specified snack items 【pre-prepared and supplied from approved / licensed sources, ready to eat after warming / reheating by electricity (excluding deep-frying and stir-frying)】*.

or **Group B**

- (1) Rice congee with meat, offal, poultry, fish, sea food or frog;
- (2) Tea, coffee, cocoa, any non-alcoholic drink or beverage made by adding water to prepared liquid or powder; and
- (3) Five self-specified snack items 【pre-prepared and supplied from approved / licensed sources, ready to eat after warming / reheating by electricity (excluding deep-frying and stir-frying)】*.

or **Group C** (any combination of the following seventeen items)

- (1) Bread, cakes and biscuits;
- (2) Toast including French toast;
- (3) Sandwiches;
- (4) Hot cakes, pancakes and waffles;
- (5) Oatmeal porridge and instant cereals;
- (6) Pastries (baking is not allowed but an electric warmer may be used to keep the pastries warm);
- (7) Eggs (boiled, poached, fried or scrambled);
- (8) Ham, bacon, western sausages, tinned meat and tinned fish;
- (9) Soup (prepared from tinned soup or powdered soup);

- (10) Macaroni / spaghetti in soup prepared from tinned soup or powdered soup;
- (11) Tea, coffee, cocoa, any non-alcoholic drink or beverage made by adding water to prepared liquid or powder;
- (12) Hot dogs;
- (13) Cold cuts (from pre-cooked meat and served cold on the premises) and vegetable / fruit salads;
- (14) Hamburgers (made from ready-to-cook hamburger meat from a licensed food factory or from a lawful source);
- (15) Jelly, tinned or prepared from jelly powder;
- (16) Instant noodles / vermicelli in soup from pre-prepared ingredients enclosed in the packet; and
- (17) Five self-specified snack items 【pre-prepared and supplied from approved / licensed sources, ready to eat after warming / reheating by electricity (excluding deep-frying and stir-frying)】*.

or **Group D** (any combination of the following ten modified items)

- (1) Bread, cakes and biscuits;
- (2) Toast excluding French toast;
- (3) Sandwiches, neither cooked nor fried;
- (4) Sausage rolls and other pastries containing pre-cooked meat (baking not allowed, but a warming oven may be permitted for warming pre-baked meat pies);
- (5) Boiled eggs;
- (6) Tea, coffee, cocoa, any non-alcoholic drink or beverage made by adding water to prepared liquid or powder;
- (7) Hot dogs;
- (8) Cold cuts (pre-cooked roast chicken and roast meat to be served cold on the premises);
- (9) Waffles; and
- (10) Five self-specified snack items 【pre-prepared and supplied from approved / licensed sources, ready to eat after warming / reheating by electricity (excluding deep-frying and stir-frying)】*.

or **Group E** (any combination of the following seven items)

- (1) Preparing sweet soup;
- (2) Double-steamed egg custard;
- (3) Jelly, tinned or prepared from jelly powder;
- (4) Soya bean curd flake (pre-prepared only);
- (5) Tea, coffee, cocoa, any non-alcoholic drink or beverage made by adding water to prepared liquid or powder;
- (6) Desserts (pre-prepared only); and

- (7) Five self-specified snack items 【pre-prepared and supplied from approved / licensed sources, ready to eat after warming / reheating by electricity (excluding deep-frying and stir-frying)】 *

or **Group F**

- (1) Speciality item (selling one food item);
- (2) Soup (prepared from tinned soup or powdered soup);
- (3) Tea, coffee, cocoa, any non-alcoholic drink or beverage made by adding water to prepared liquid or powder; and
- (4) Five self-specified snack items 【pre-prepared and supplied from approved / licensed sources, ready to eat after warming / reheating by electricity (excluding deep-frying and stir-frying)】 *.

Remarks: * **Please refer to “Specified Snack List”**

Specified Snack List

(Chinese Snack)

Item No.	Name of Snack Item	Item No.	Name of Snack Item	Item No.	Name of Snack Item
1	Lo shui duck gizzard	24	Deep fried savoury triangle	47	Red bean glutinous rice ball
2	Lo shui chicken gizzard	25	Shrimp dumpling	48	Sesame paste bun
3	Lo shui sliced beef	26	Steamed beef ball	49	Red bean bun
4	Lo shui chicken wing	27	Chicken with Chinese ham and maw	50	Leaf lard bun
5	Boiled egg in tea	28	Chicken claw	51	Egg-yolk and cream bun
6	Spring roll	29	Siu mai	52	Soya bean curd flake
7	Steamed meat bun	30	Steamed sparerib	53	Twisted doughnut
8	Steamed bread	31	Pickled chicken claw	54	Ox tongue crisp
9	Sesame seed cake	32	Chicken claws in black bean sauce	55	Sesame cookie
10	Green onion coil	33	Pan-fried chicken wing	56	Spicy doughnut
11	Vegetarian lo mei	34	Fish ball	57	Shrimp ricesheet roll
12	Snow ball	35	Beef ball	58	Vegetarian ricesheet roll
13	Red bean pudding	36	Pork ball with minced mushroom	59	Barbecued meat ricesheet roll
14	Split peas pudding	37	Cuttlefish ball	60	Beef ricesheet roll
15	Coconut milk pudding	38	Glutinous rice with salted pork	61	Shui Kau
16	Multi layers cake	39	Rice dumpling with lye	62	Steamed dumpling in Chiu Chow Style
17	Turnip pudding	40	Barbecued meat bun	63	Fish dumpling
18	Taro pudding	41	Vegetable meat bun	64	Soup
19	Jelly fish	42	Beef bun	65	Dumpling
20	Deep fried taro pastry	43	Steamed bread roll	66	Chive dumpling
21	Steamed rice dumpling	44	Stuffed dumpling in green wrapping	67	Fresh soyabean sheet roll
22	Mini steamed rice dumpling	45	Sweetened dough	68	Dried soyabean sheet roll
23	Glutinous rice roll	46	Sesame paste glutinous rice ball	69	Seasame roll
				70	Pre-cooked rice dumpling

Specified Snack List

(Non-Chinese Snack)

Item No.	Name of Snack Item	Item No.	Name of Snack Item	Item No.	Name of Snack Item
1	Sweet coconut bread	19	Brochette of chicken	37	Vegetable salad
2	Pineapple bun	20	Barbecued mackerel pike	38	Curry kok (Samosa)
3	Dinner bun	21	Pineapple and sausage	39	French fries
4	Mango pudding	22	Raisin muffin	40	Smoked salmon
5	Sago pudding	23	Corn beef croissant	41	Frozen (cooked) shrimp meat
6	Fruit pudding	24	Ham and cheese croissant	42	Frozen (cooked) crab meat
7	Butter puff	25	Egg and tomato sandwich	43	Chicken nuggets
8	Cheese cake	26	Beef sandwich	44	Mixed vegetable in beef roll
9	French bread	27	Ham sandwich	45	Stir fried mixed mushroom in olive oil
10	Baked potato (single filling)	28	Ham and cheese sandwich	46	Juicy beef salad
11	Boiled egg	29	Pizza (single-flavoured topping)	47	Cold noodles with sesame dressing
12	Waffle with butter and syrup	30	Jelly	48	Crab roe and mango salad
13	Goose liver roll	31	Chicken pie	49	Frozen omelet
14	Duck meat roll	32	Pancake		
15	Sausage roll	33	Waffle		
16	Brochette of pork	34	Toast		
17	Hot dog	35	Egg tart		
18	Brochette of beef	36	Toasted bread with cheese and cream		

Notes:

- (1) All items for sale and their respective prices shall be prominently displayed at the Permit Area.
- (2) A Service Provider may offer for sale any other commodity which is compatible with the licensing requirement relating to the Light Refreshment Restaurant Business.
- (3) It is not the intention of the Government Representative to exercise control over the prices of commodities for sale at the Permit Area.

SCHEDULES

Third Schedule

Information on Service Provider

Service Provider is required to provide the following information –

1. If my/our quotation is accepted, I/we shall, pursuant to Clause 13(a) of the Notes for Service Provider, deposit with the Government of the Hong Kong Special Administrative Region, not later than seven (7) days before the commencement of the Term or at such time as shall be directed by the Government Representative, a sum equivalent to four (4) months' Monthly Permit Fee as security for the due and faithful performance of the Agreement either –
 - (a) in cash; or
 - (b) in the form of a banker's guarantee approved by the Government Representative and issued by a bank licensed under Section 16 of the Banking Ordinance (Cap. 155). I/We shall keep the banker's guarantee valid for three (3) more months after the expiry of this Agreement.

Signature of Service Provider
or Authorized Representative*: _____
(with Service Provider's chop, if applicable)

Date : _____

* Delete as appropriate

2. In support of my/our offer for the grant of the Permit, I/we would provide the following information –

(A) Service Provider's Status

- (1) If the Service Provider is a Sole Proprietor** – (If the Service Provider is not a sole proprietor of the business he is bidding for, please strike out (1) and go to (2). If the Service Provider is a sole proprietor, please complete (1) and strike out (2) and (3).)

(a) Name of Owner/Proprietor: (in English) _____
(in Chinese) _____

(b) Hong Kong Identity Card Number: _____

(c) Residential address: _____

(d) Telephone number: _____
Facsimile number: _____

(e) Length of experience in operating the business bidding for: _____

(f) Business Registration Certificate Number of the business being operated (if any): _____

Expiry date of Business Registration Certificate (if applicable): _____

(g) Name of Banker and Branch dealing with the business being operated: _____

Address of Banker and Branch: _____

Bank Account Number: _____

(h) I submit this quotation for and on my own behalf as the sole proprietor with details as shown above. I also attach herewith documentary evidence proving my possession of the requisite relevant experience.

Signature of Owner/Proprietor (i.e. the Service Provider): _____

Date: _____

(2) If the Service Provider is a Firm or other Body Unincorporated - (If the Service Provider is a body corporate, please strike out (2) and go to (3).)

(a) Name of the Firm / (in English) _____
Body Unincorporated : (in Chinese) _____

(b) Address of the Firm / Body Unincorporated : _____

(c) Telephone number: _____ Facsimile number: _____

(d) Length of experience in operating
the business bidding for: _____

(e) Business Registration Certificate
Number of the business being
operated: _____

Expiry date of Business
Registration Certificate: _____

(f) Name of Banker and Branch dealing with the business being operated:

Address of Banker and Branch:

Bank Account Number: _____

(g) Names of all Partners (in BLOCK letters)(a copy of partnership agreement shall be submitted if the Service Provider is a partnership or office-bearers of body unincorporated) :

Residential address(es) of Partners or office-bearers (in above order):

(h) I declare and confirm that I am one of the partners / the authorized representative of the said firm / body unincorporated and am duly authorized to bind the said firm / body unincorporated and all its partners to this quotation by my signature. I attach to the Quotation Form a letter certifying that I am the authorized representative to sign contracts / agreements. I also attach herewith documentary evidence proving my / our possession of the requisite relevant experience.

Signature of Authorized Representative:

(with firm / body unincorporated chop)

Name of Authorized Representative:

Date:

(3) If the Service Provider is a Body Corporate –

(a) Name of the Body Corporate: (in English) _____

(in Chinese) _____

If a Subsidiary, Name of Parent Company:

(in English) _____

(in Chinese) _____

(b) Address of registered office:

(c) Telephone number: _____ Facsimile number: _____

(d) Length of experience in operating the business bidding for: _____

(e) Certificate of Incorporation Number of the company or name of ordinance under which the body corporate is established: _____

Limited or unlimited liability: _____

Year of establishment: _____

(f) Business Registration Certificate
Number of the business being
operated: _____

Expiry date of Business Registration
Certificate: _____

(g) Name (in BLOCK letters) and residential address of the Managing Director:

(h) Name (in BLOCK letters) and residential address of the Company Secretary:

(i) Name of Banker and Branch dealing with the business being operated:

Address of Banker and Branch:

Bank Account Number: _____

(j) I declare and confirm that I am the *Managing Director/Company Secretary/Principal Officer (please specify _____)# of the said company/body corporate and am duly authorized to sign this Information on Service Provider on behalf of the said company/body corporate and to bind the said company/body corporate by my signature. I attach to the Quotation Form a certified true copy of the company's resolution/body corporate minutes of meeting showing that I am duly authorized to sign contracts/agreements. I also attach herewith documentary evidence proving our possession of the requisite relevant experience.

Signature of Authorized
Representative: _____

(with company/body corporate chop)

Name of Authorized Representative: _____

Date: _____

Please fill in the blank.

(B) Past Experience

Description and history (with dates) of past experience in the relevant business (if there is not enough space, please use separate sheets) and documentary proofs e.g. licences issued by the Food and Environmental Hygiene Department, Business Registration Certificates, entire set of contracts, reference letters, etc., which can show that the Service Provider has the minimum years of experience in operating any of the catering business and Boat Hiring Business as required under Clause 14(a)(ii) of the Notes for Service Provider –

(C) Other business being run at present –

(D) Proposed investment for the Light Refreshment Restaurant, Light Refreshment and Boat Hiring Business –

(E) Proposed number of staff to be employed for operating the Light Refreshment Restaurant, Light Refreshment and Boat Hiring Business –

(F) Other information relevant to my/our quotation –

3. In the event of any queries relating to my/our offer, please contact:

Name: _____ Telephone number: _____

Name(s) and address(es) of Service Provider or Authorized Representative signing this document :

Telephone number: _____

Signature of Service Provider
or Authorized Representative* : _____
(with Service Provider's chop, if applicable)

Date : _____

* Service Provider must delete as appropriate.

- Notes:
- (i) All the particulars required above shall be accurately completed and the supply of any untruthful particulars or wilful omission may lead to rejection of this quotation.
 - (ii) Any alternatives, which are not applicable, should be struck out.
 - (iii) Service Provider should read carefully each and every part of the Quotation Documents.
 - (iv) If the Service Provider is a sole proprietor, the Service Provider shall answer queries and sign the Quotation Documents personally and shall not authorize any other person to act for the Service Provider. If the Service Provider is a firm or an unincorporated body, the Service Provider may authorize a partner(s) of the firm or an office-bearer of a body unincorporated to answer queries and sign the Quotation Documents.
 - (v) If the Service Provider is a firm, an unincorporated body, a company or other body corporate, he shall submit with the quotation a copy of the minutes of meeting and/or resolution of the board of directors to prove proper authorization of the person(s) or representative(s) to act on behalf of the Service Provider and sign the Quotation Documents. If the Service Provider is a partnership, one of the partners may sign the Quotation Documents save and except that all partners shall execute the Permit.
 - (vi) The information provided will be used solely for processing of this quotation exercise.

SCHEDULES**Fourth Schedule A****List of appliances, furniture, fixtures and fittings
provided by the Government for the Light Refreshment Restaurant Business
at Wong Nai Chung Reservoir Park**

Item	Description	Quantity
1	Cooker-hood	1 no.
2	Sink	2 nos.
3	Grease trap	1 no.
4	Automated External Defibrillator (AED) and associated parts	1 set

SCHEDULES**Fourth Schedule B****List of appliances, furniture, fixtures and fittings
provided by the Government for the Light Refreshment Business
at Wong Nai Chung Reservoir Park**

Item	Description	Quantity
1	Sink	1 no.

SCHEDULES

Fifth Schedule A

List of Boats that the Service Provider will offer for hire

Description

1. Row Boat
2. Pedal Wheel Boat (1 seat)
3. Pedal Wheel Boat (2 seats)
4. Pedal Wheel Boat (4 seats)
5. Radio Controlled & Battery-Operated Model Boat

Notes:

- (1) All items for hire and their respective prices must be prominently displayed at the Permit Area.
- (2) Service Provider shall not offer for hire any item which is not listed in this schedule or has not been approved by the Government Representative.
- (3) It is not the intention of the Government Representative to exercise control over the prices of the items for hire at the Permit Area.

SCHEDULES

Fifth Schedule B

**Design and Specifications of
Row Boat**

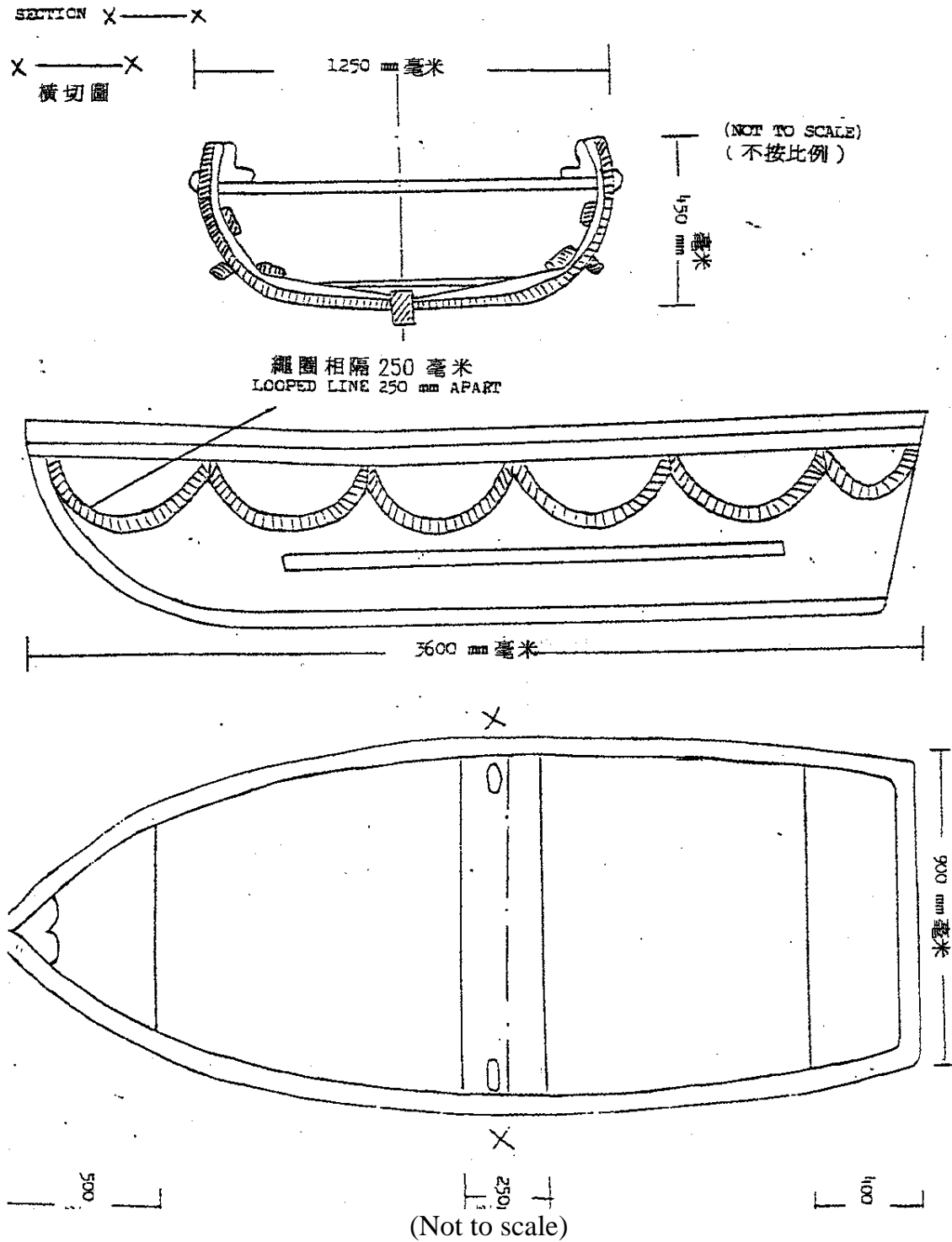

SCHEDULES

Fifth Schedule C

**Design and Specifications of
Pedal Wheel Boat**

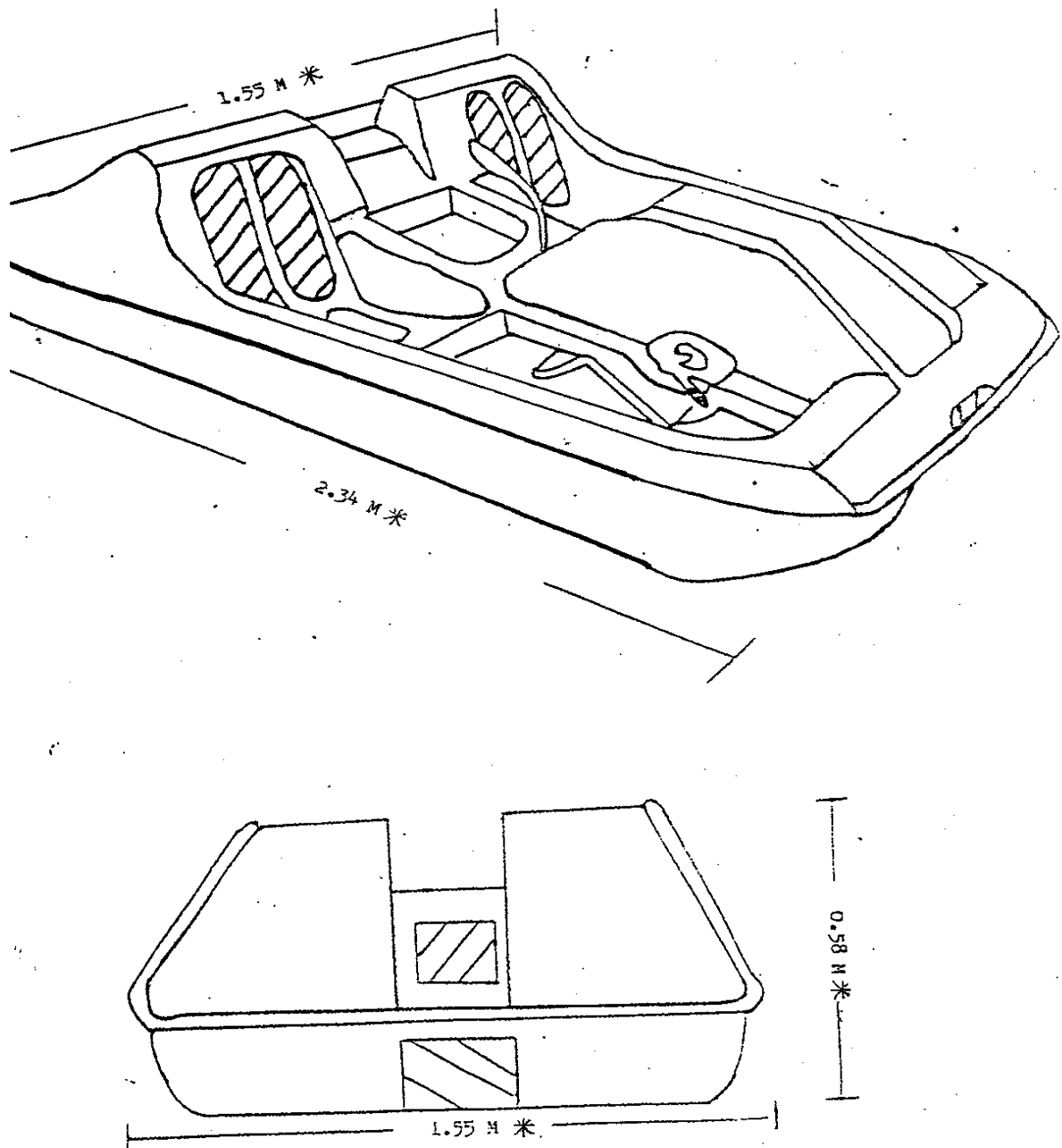

(Not to scale)

SCHEDULES

Fifth Schedule C

**Design and Specifications of
Pedal Wheel Boat**

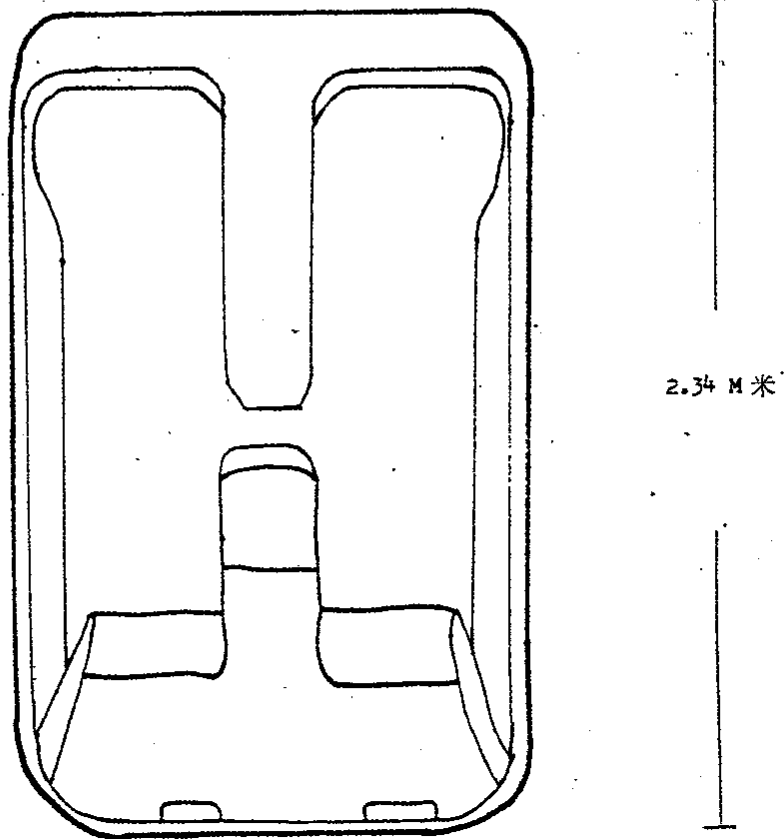
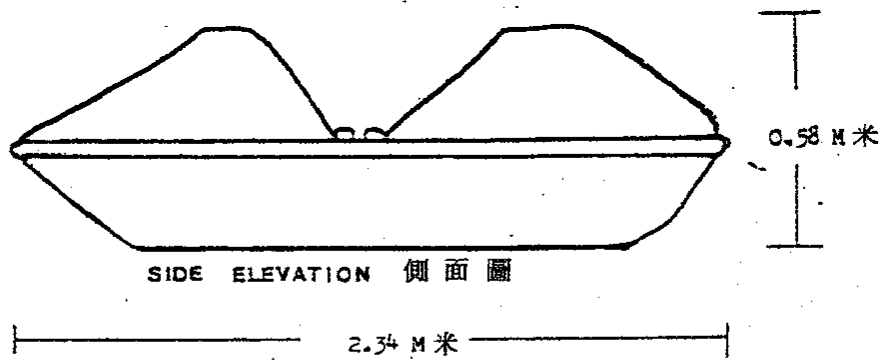

(Not to scale)

SCHEDULES

Fifth Schedule D

**Design and Specifications of
Radio Controlled & Battery-Operated Model Boat**

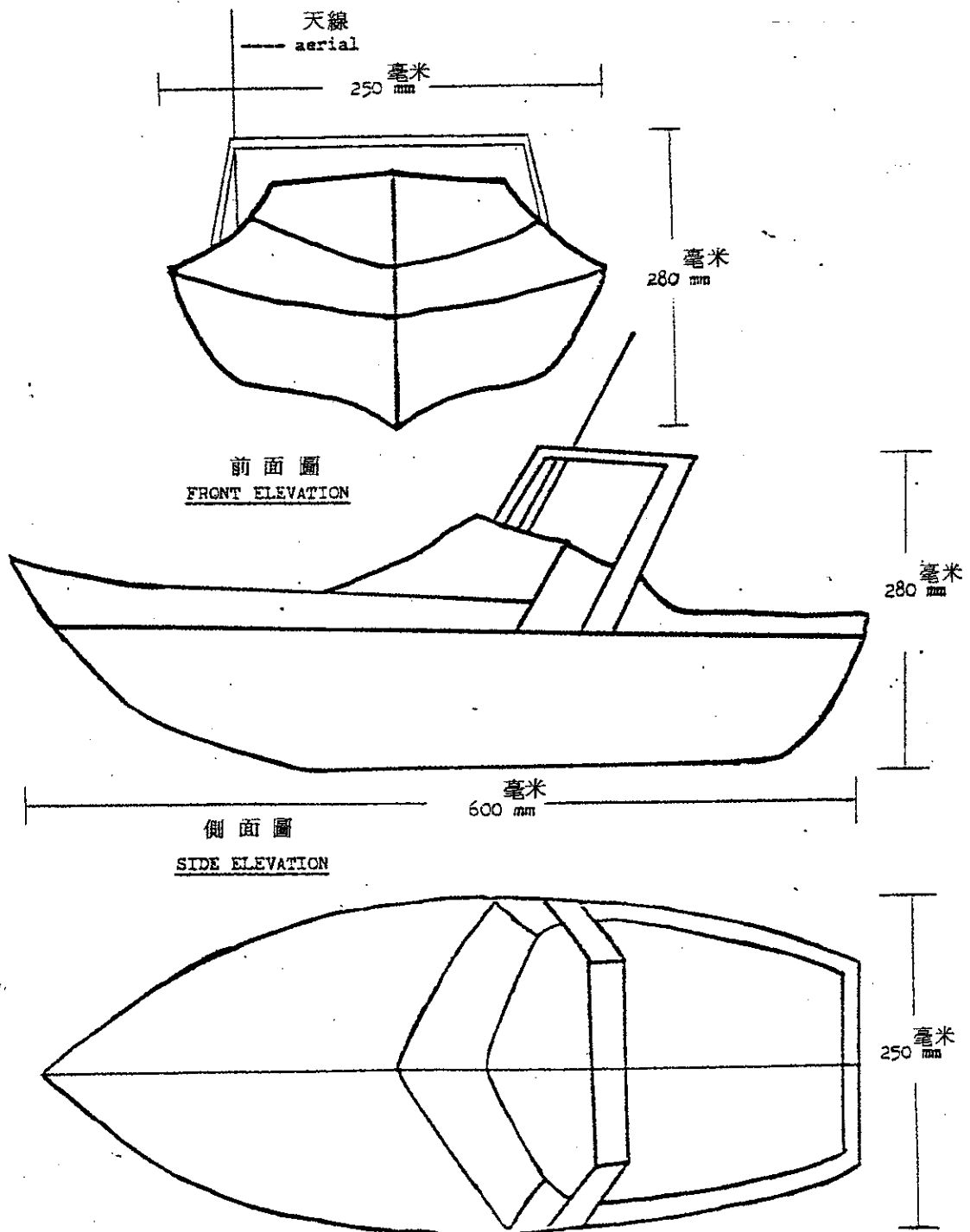

(Not to scale)

SCHEDULES**Sixth Schedule****List of First Aid Equipment to be provided by the Permit Holder at the Venue**

Description	Quantity
A. Stretcher and blanket	optional and subject to availability of space
B. First aid box <ul style="list-style-type: none"> ● Case made of molded copolymer with 2 divider trays linked by two stainless steel latched that allows the trays to stay latched for easy access, ● Two cantilevered lock at front panel of case allow the case to be opened or closed by simple pull-snap action, ● A padlock eye should be provided that allows the contents to be sealed, ● A luggage type handle should be provided, ● The size of case should be 27.3cm x 48.3cm x 25.7cm 	1 no.
C. First Aid Kit and Materials to be maintained in the Box <ol style="list-style-type: none"> 1. Structural Aluminum Malleable splint/Inflatable splint 2. Stainless steel scissor, 12cm blunt 3. Stainless steel forceps, 12cm blunt 4. Plastic kidney dish 5. Measuring jug with lid for disinfectant hospital concentrate 6. Cold pack/Instant cold pack (if fridge not available) 7. Infra-red thermometer 8. Safety pin large 9. Triangular bandage 10. Elastic crepe bandage (5.0cm) 11. Cotton gauze bandage (5.0cm) 12. Sterile gauze pad (5.0 x 5.0cm, 7.5 x 7.5cm) 13. Sterile eyes pad 14. Cotton wool 15. Water-proof plastic strip 16. Non-allergic surgical tape (1.25cm) 	1 no. 1 no. 1 no. 1 no. 1 no. At least 2 packs 1 no. 1 box 1 pack 1 pack 1 pack 1 pack 1 pack 1 pack

17. Disposable gloves	2 pairs
18. Disinfectant Hospital concentrate with dispensing pump (5 lit/drum)	1 no.
19. Eye Aid (Irrigation solution)	1 bottle
20. Antiseptic wipes	1 bottle
21. Antiseptic pain relief spray (use with cautions: observe the expiry date and avoid abusive use)	1 bottle
22. Salt tablets	1 box
D First aid booklet	1 no.

Notes :

- (1) A list of the type and quantity of first aid equipment provided at the Venue must be prominently displayed at the Permit Area for checking by the Government Representative.
- (2) The Permit Holder shall abide by any directions as to the type and quantity of first aid equipment including but not limited to provision / maintenance / removal of specific equipment as may be given by the Government Representative from time to time.

AGREEMENT

THIS AGREEMENT made this _____ day of _____ 2017 BETWEEN the Government of the Hong Kong Special Administrative Region acting through the Director of Leisure and Cultural Services whose principal office is situated at the Leisure and Cultural Services Headquarters, 1-3 Pai Tau Street, Sha Tin, Hong Kong (the ‘Government’) of the one part AND _____ [name of Permit Holder] of _____ [address of Permit Holder] (the ‘Permit Holder’) of the other part.

THE PARTIES HERETO agree as follows –

1. The Government hereby grants to the Permit Holder a Permit to conduct Light Refreshment Restaurant, Light Refreshment and Boat Hiring Business in the Permit Area at Wong Nai Chung Reservoir Park for the period and on the terms and conditions set out in the following documents –
 - (i) Quotation Form;
 - (ii) Interpretation;
 - (iii) Notes for Service Provider;
 - (iv) Conditions of Contract; and
 - (v) Schedules and Annexes.

2. In consideration of the grant of the Permit, the Permit Holder agrees to pay to the Government the Monthly Permit Fee and to observe and perform the terms and conditions of this Agreement.

THE PARTIES HERETO have set their hands the day and year first before written.

Signed for and on behalf of the Government of the)
 Hong Kong Special Administrative Region by)
 (name and post))

in the presence of)
 (name and post))

Signature of the Permit Holder/Authorized)
 Representative*)
 (name and HKIC no. of the Permit Holder /Authorized)
 Representative*))
 (with firm/company chop, if applicable))

in the presence of)
 (name and HKIC no.))

* Delete as appropriate

ANNEXES

ANNEX A

Location Plan of the Venue at Wong Nai Chung Reservoir Park

(Venue as delineated and shown edged green)

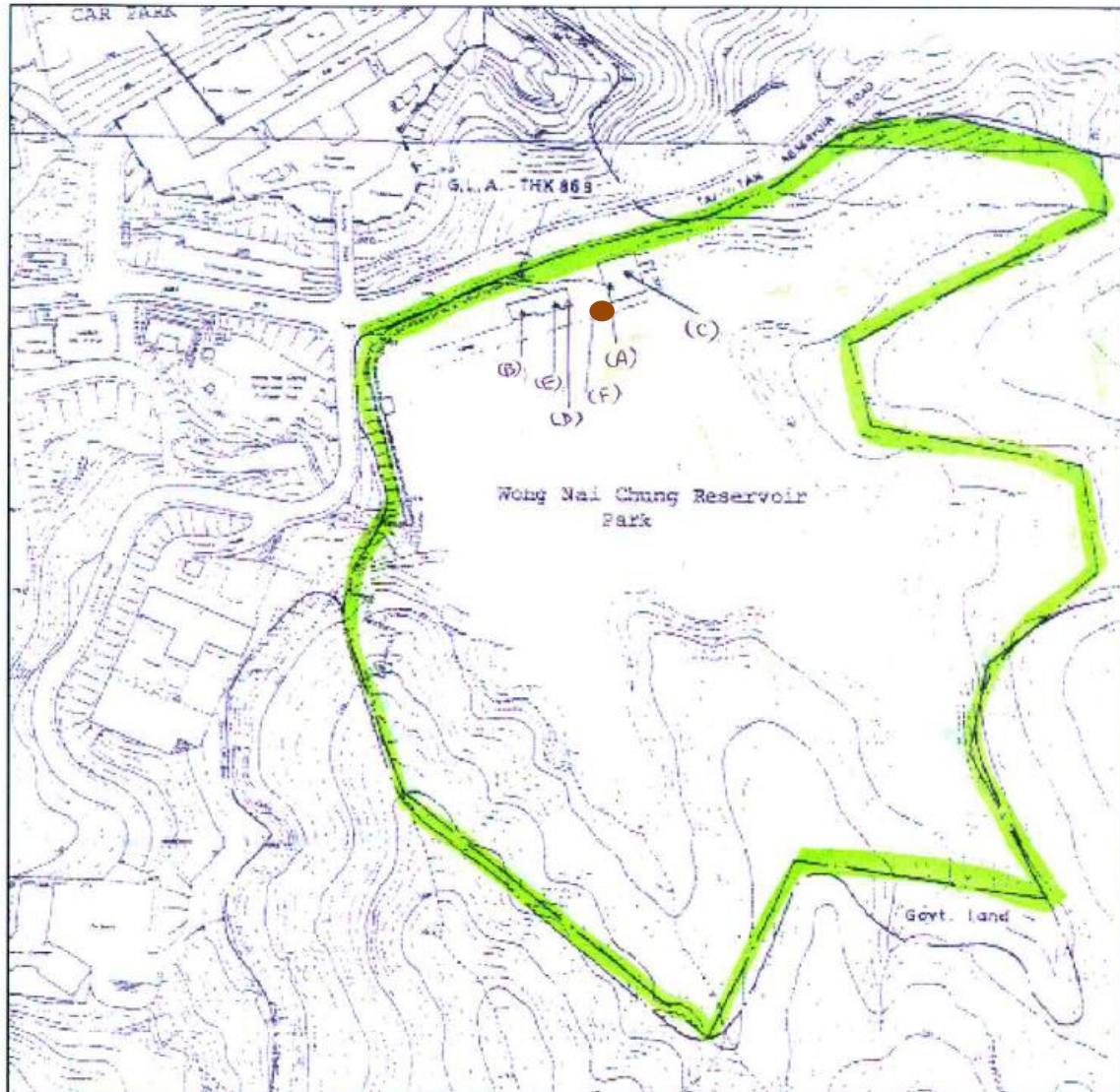

(Not to scale)

LEGEND

- (A) : The Boat Hiring Office
- (B) : The Boat Shed
- (C) : The Light Refreshment Restaurant
- (D) : The Waiting Area
- (E) : The Light Refreshment Kiosk
- (F) : The Lookout Tower

ANNEXES

ANNEX B

**Layout Plan Showing the Boat Hiring Office at
Wong Nai Chung Reservoir Park**

(Permit Area for the Boat Hiring Business as delineated and shown coloured red)

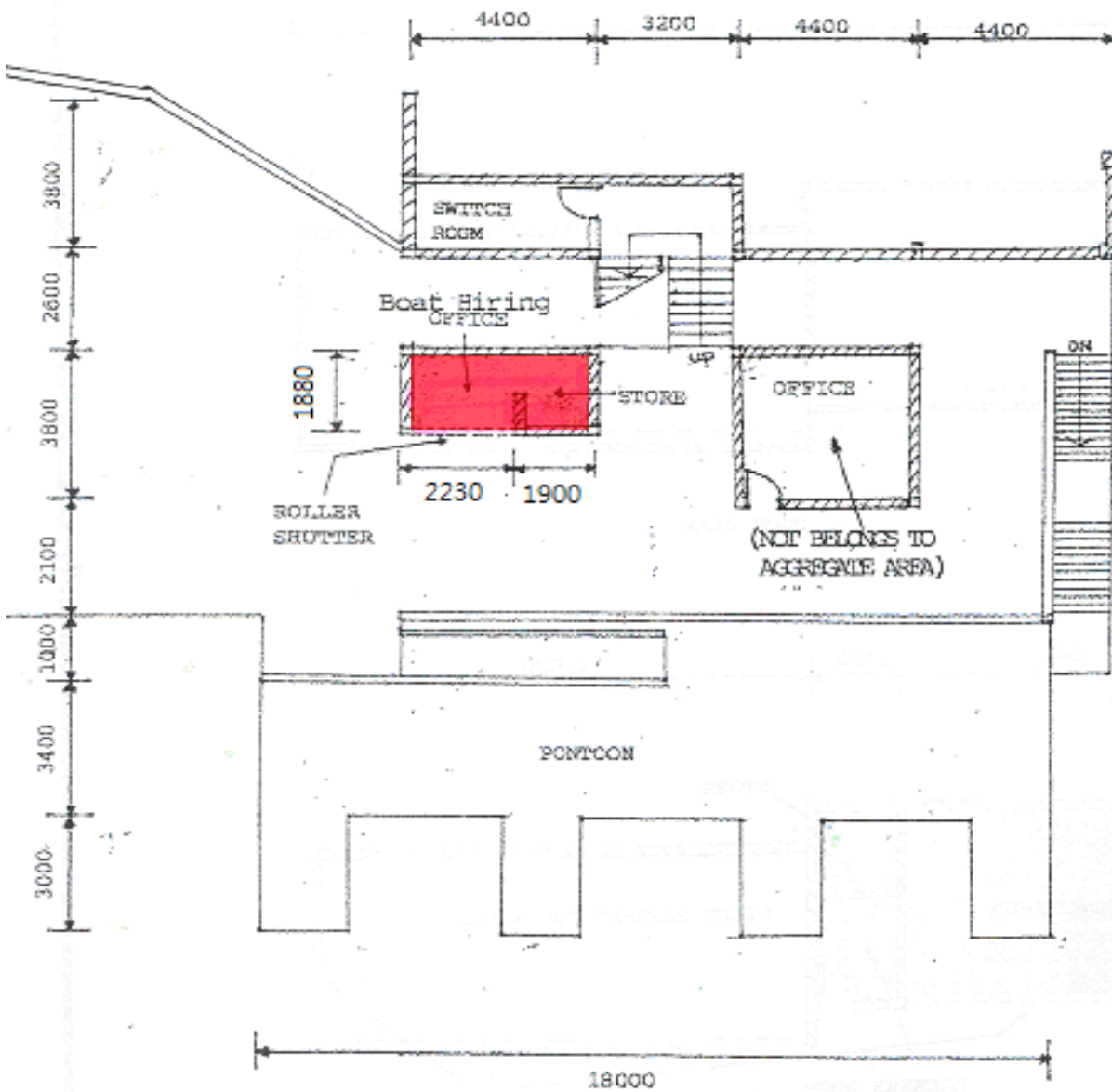

DECK FLOOR PLAN

(Not to scale)

ANNEXES

ANNEX C

**Layout Plan Showing the Boat Shed and Waiting Area
at Wong Nai Chung Reservoir Park**

(Permit Area for the Boat Shed as delineated and shown coloured red)

(Permit Area for the Waiting Area as delineated and shown coloured yellow)

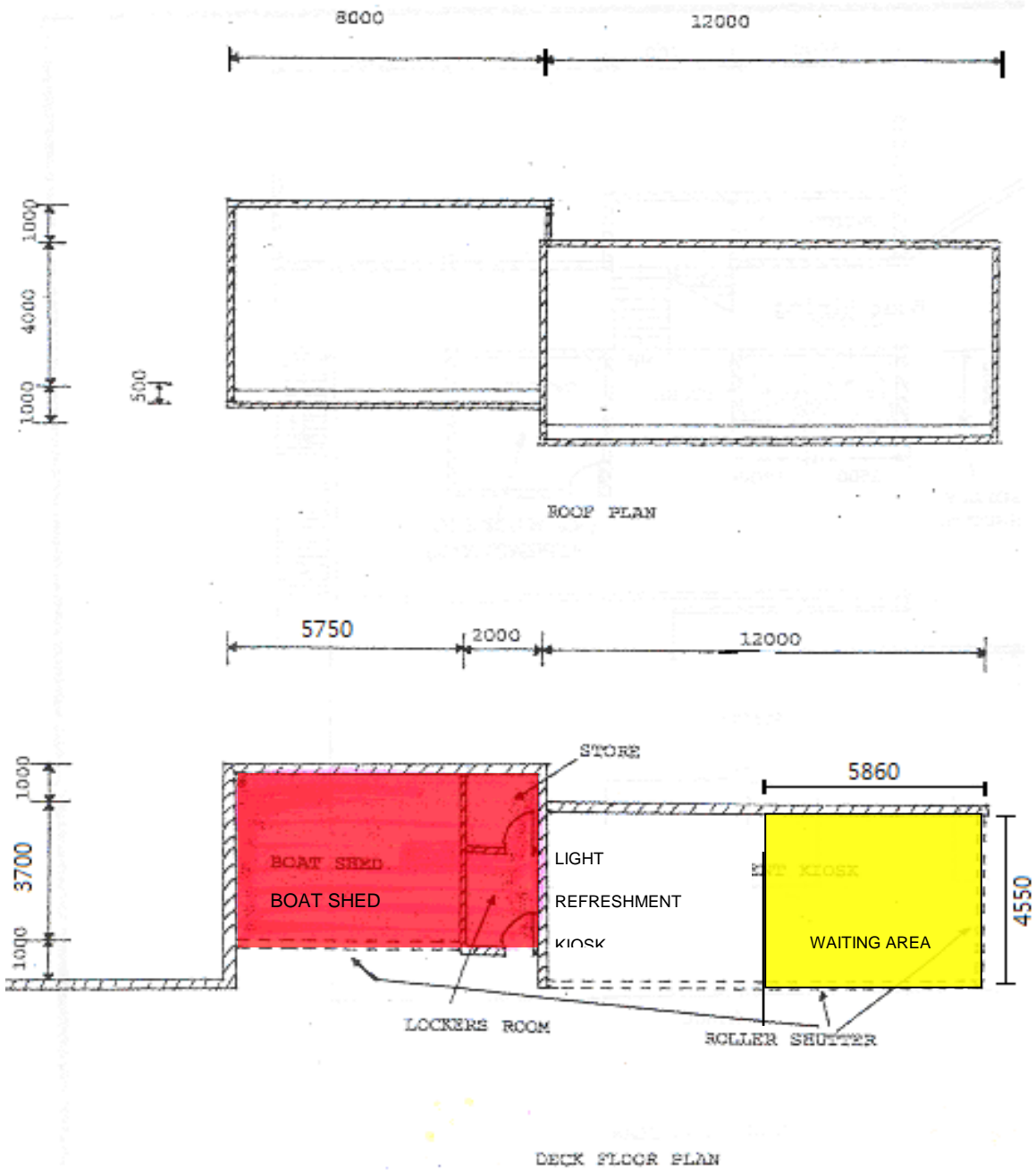

(Not to scale)

ANNEXES

ANNEX D

Layout Plan Showing the Light Refreshment Restaurant at Wong Nai Chung Reservoir Park

(Permit Area for the Light Refreshment Restaurant Business as delineated and shown coloured red)

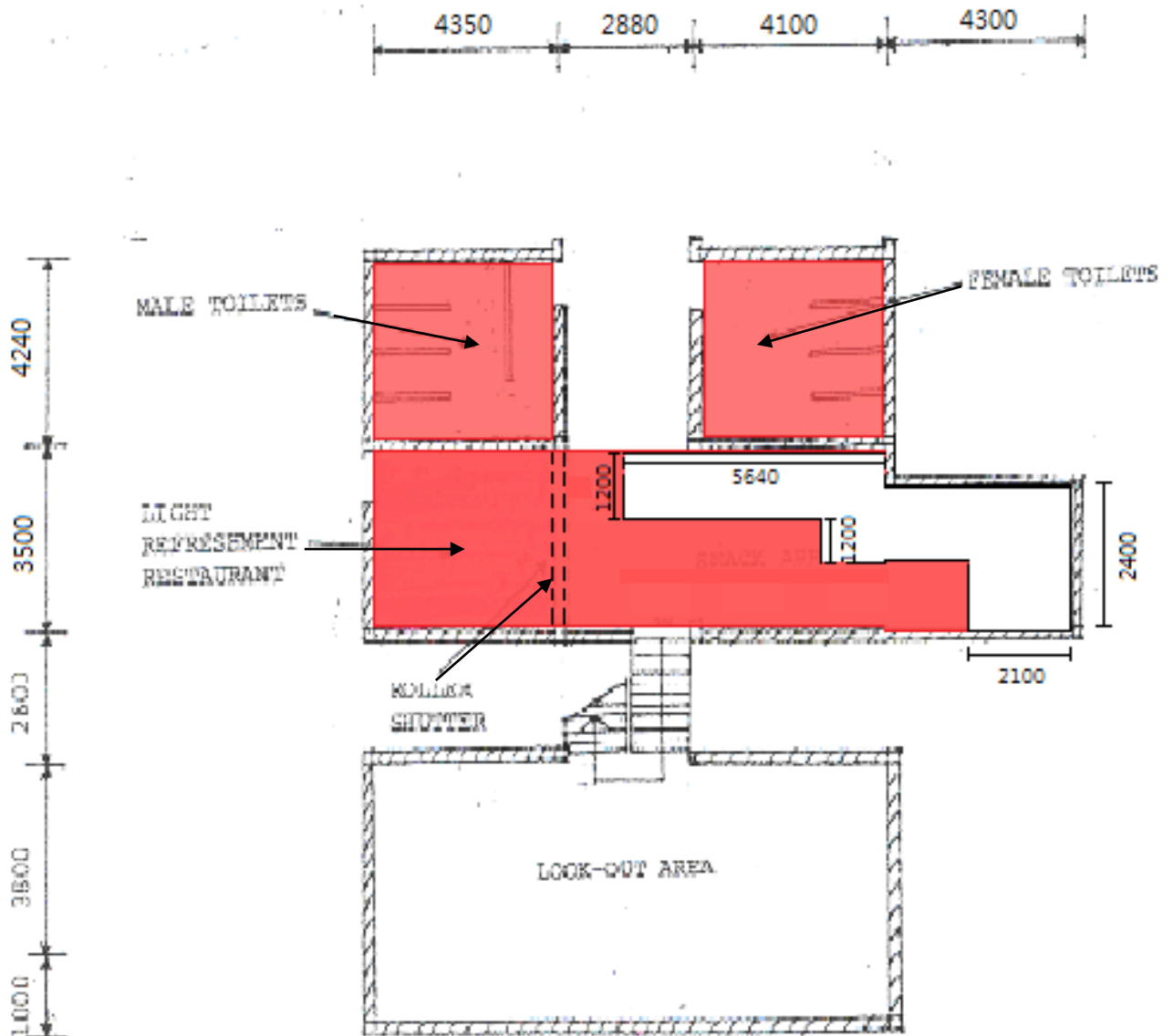

GROUND FLOOR PLAN

(Not to scale)

ANNEXES

ANNEX E

Layout Plan Showing the Light Refreshment Kiosk

at Wong Nai Chung Reservoir Park

(Permit Area for the Light Refreshment Business

as delineated and shown coloured red)

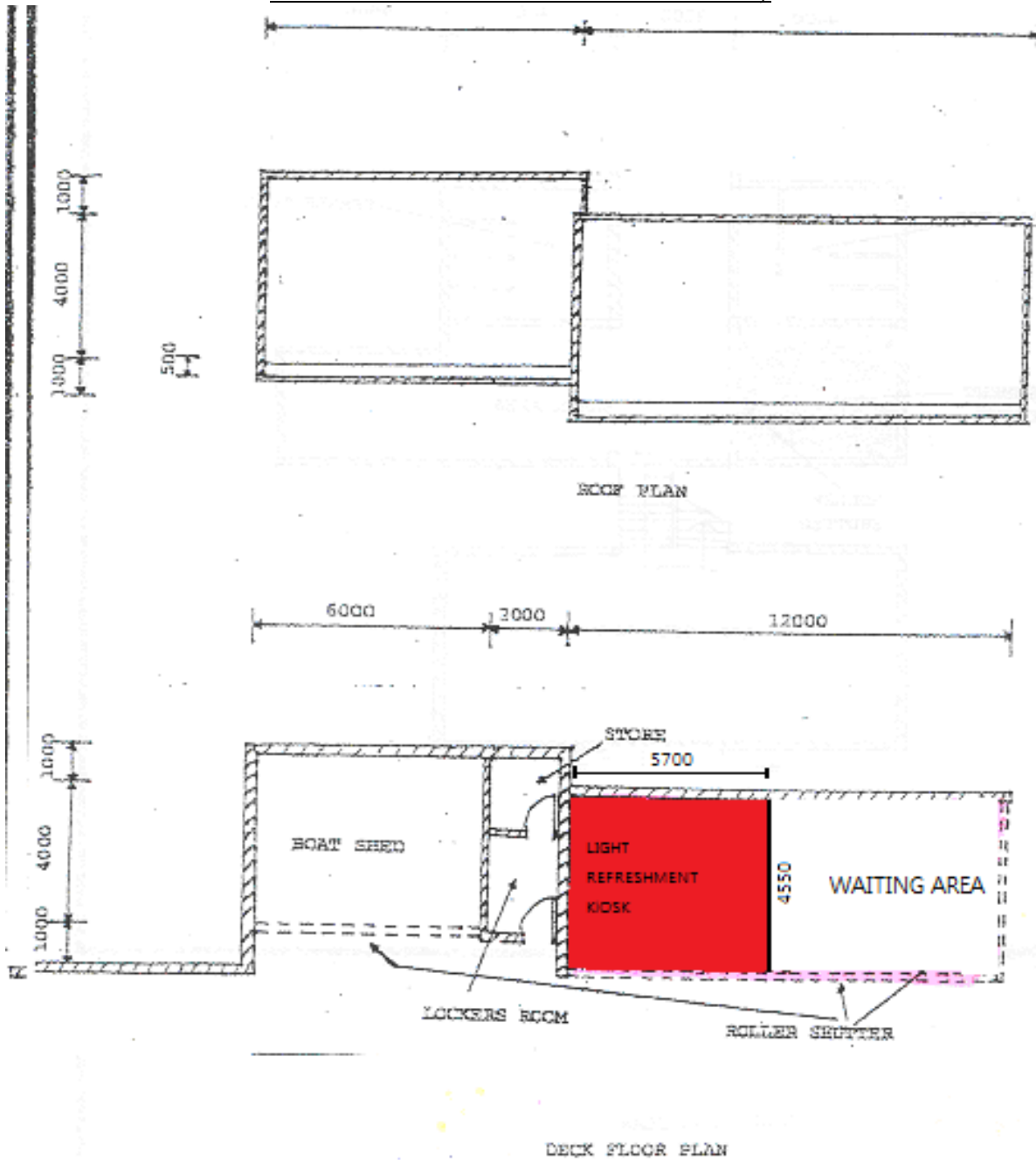

(Not to scale)

ANNEXES

ANNEX F
Layout Plan Showing the Declared Monuments
at Wong Nai Chung Reservoir Park
 (Declared Monuments in the Venue as delineated and shown edged red)

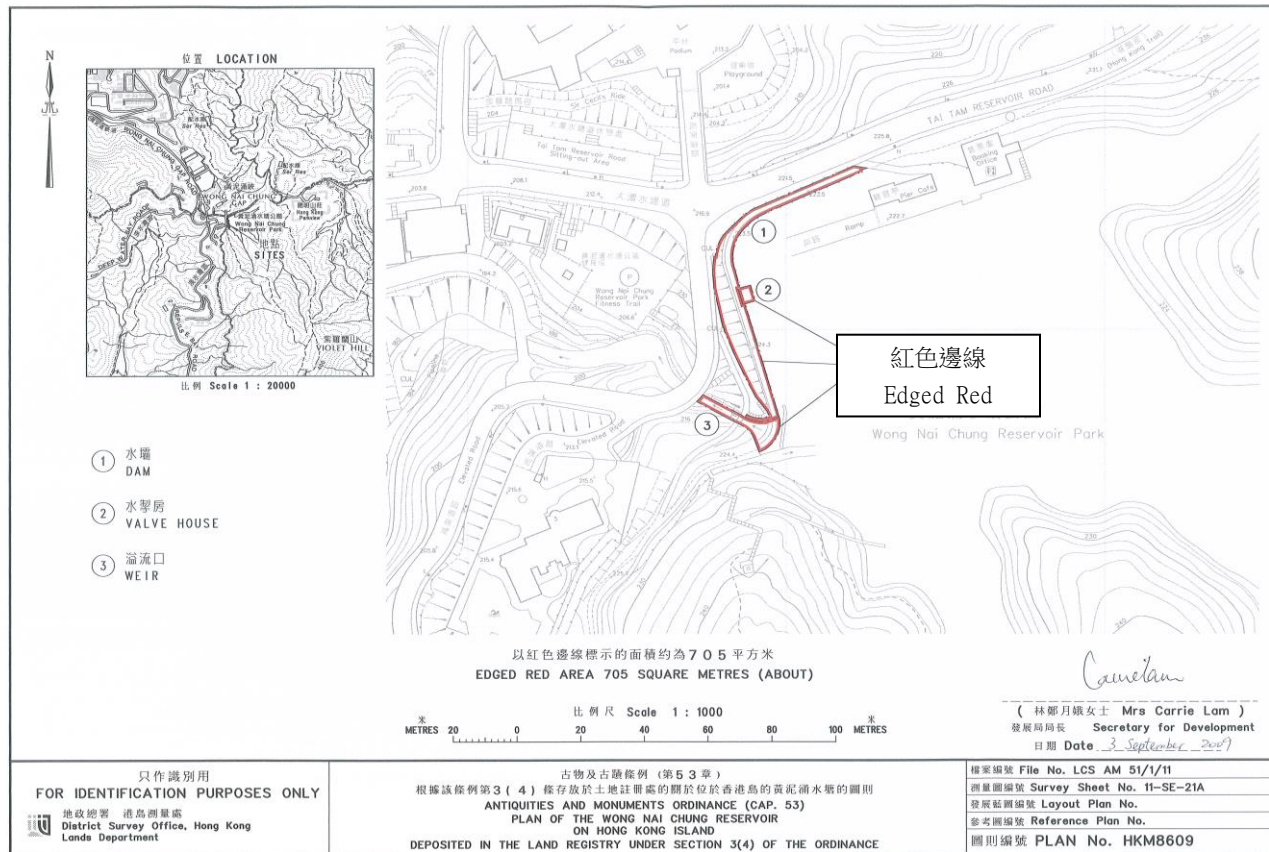

(Not to scale)